

Card Laminator

L10D

Instruction Manual

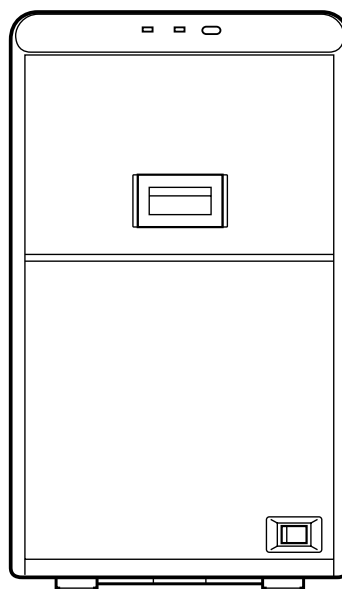

Thank you for purchasing this product.
Please read through this "Instruction Manual" carefully in advance to ensure proper use of the product. Also, to make sure that the product is used safely, please read through the "Safety Precautions". Please store the manuals properly after reading so that they can be referred to whenever necessary.

Characteristics of this Unit

- This laminator attaches a protective layer to one or both sides of the card printed by the card printer.
- A hologram that helps to enhance the security level of the card can be formed on the protective layer.
- This laminator can be made to operate in conjunction with the card printer unit through infrared communication.
- It is built in with a function for adjusting the lengthwise position of the laminate film, which enables easy adjustment of the patch in the front-back direction.

Contents

Before Use

Characteristics of this Unit	2
Contents	2
Safety Precautions	4
About this Manual	6
Precautions During Use	6
Capability of this Unit	7
Name and Functions of Parts.....	7
Internal Mechanism Diagram	9
Specifications	10
Accessories/Products Sold Separately	10

Setup

Installation and Connection.....	11
Setting Laminate Film	12

Operating the Laminator

Operation Panel	14
Initializing	17
Turning On the Power.....	18
Turning Off the Power.....	18
Firmware Update.....	19

Settings

Status Monitor Settings	20
Printer Driver Settings	22

Replacement

Laminate Film.....	23
--------------------	----

Maintenance

Card Feed Roller/Heating Roller	25
Fan Filter	28
Film Cassette	28
Interior of Laminator	30

Troubleshooting

Card Jam.....	32
Film is Entangled.....	34
Misaligned Patch Position	35
Card Warpage.....	36
List of Error Codes	38

In case of disposal

In case of disposal this unit, take care for compliance with the local law and regulations in your country.

**Read through the following carefully before operating to ensure proper use of this laminator.
After reading, store this manual at a place that can be easily retrieved when necessary.**

Information for USA

For a Class A digital device or peripheral, the instructions furnished the user shall include the following or similar statement, placed in a prominent location in the text of the manual:

Note: This equipment has been tested and found to comply with the limits for a Class A digital device, pursuant to part 15 of the FCC Rules. These limits are designed to provide reasonable protection against harmful interference when the equipment is operated in a commercial environment. This equipment generates, uses, and can radiate radio frequency energy and, if not installed and used in accordance with the instruction manual, may cause harmful interference to radio communications. Operation of this equipment in a residential area is likely to cause harmful interference in which case the user will be required to correct the interference at his own expense.

Caution: Changes or modifications not approved by party responsible for compliance could void user's authority to operate the equipment.

Information for Canada

Operation is subject to the following two conditions:

(1) this device may not cause interference, and (2) this device must accept any interference, including interference that may cause undesired operation of the device.

Information for EU



Machine noise

Sound power level: less than 70dB(A) according to DIN45635 part 19 (EN27779).

The measurements are to be made according to DIN45635 part 2019 or EN27779, respectively.

Safety Precautions

WARNING

■ If you ignore the warning with this mark, and handle the unit in a wrong way, death or serious injuries may occur.

CAUTION

■ If you ignore the caution with this mark, and handle the unit in a wrong way, injuries or damages to properties may occur.

WARNING

■ If the abnormal phenomena as listed below are seen, immediately stop operating the unit. Continuing operation may cause a fire or electric shock.

- Smoke or odd smell comes out from the machine.
- Water or metal went into the machine.
- The unit fell to the floor, or the cabinet was broken.
- The power cable is damaged (exposed lead, broken cable, etc.)

If you see these phenomena, turn off the power, pull out the power plug, and contact your dealer as soon as possible. Do not try to repair it by yourself. It is dangerous.

■ Do not remove the screws, or disassemble or alter the machine.

- High-voltage components are contained in the unit. Touching these areas may result in an electric shock.
- Ask your dealer if you want your laminator inspected or repaired.
- Do not remove the external covers of the machine. You may get an electric shock.

■ Do not work on the power cable, or give excessive force on it. Do not put heavy objects such as furniture on the cable.

- The cable may be damaged, causing a fire or electric shock.
- When you find a defect on the power cable, such as exposed lead, stop using the unit, and consult your dealer.

■ Do not use the machine with the power plug inserted incompletely.

- The machine generates heat due to incomplete contact, causing a fire or electric shock.
- Do not put many cords on a single plug socket. The power cords also heats up.

■ Do not use the machine with dusts piled on the power plug. Do not put a metallic material adjacent to the power plug.

- Dusts and metal are conductive, causing a fire or electric shock.
- Pull out the power plug from the outlet every six months, and clean the dusts piled on the legs and body of the plug.

■ Do not use a line voltage other than instructed.

- Using a line voltage or power supply which is not specified may cause a fire or electric shock.

■ Do not put foreign materials from the openings of the machine (e.g., vents, card slots, cassette inlet, etc.)

- Metals, flammable things, and other foreign materials may cause a fire or electric shock if entering into the machine.
- If these things went into the machine, immediately turn off the power, pull out the power plug, and ask your dealer to repair. Do not try to repair it by yourself. It is dangerous.

■ Do not put a container with liquid in it, or small metal ornaments and the like on the machine.

- The liquid or metal entering into the machine acts as a conductor, causing a fire or electric shock.
- If liquid or metal went into the machine, immediately turn off the power, pull out the power plug, and ask your dealer to repair. Do not try to repair it by yourself. It is dangerous.

■ Do not place the machine on a rickety table or slanting places.

- The machine may fall out of the table or fall over, which may damage the machine or injure you.
- If the machine is damaged by falling or turnover, immediately turn off the power, pull out the power plug, and ask your dealer to repair. Do not try to repair it by yourself. It is dangerous.

■ Do not wet the machine with water.

- Using the machine at a place where water splashes on the machine, or wetting the machine with water (applying, throwing, or spilling water over the machine) may cause a fire or electric shock.
- If water entered into the machine, immediately turn off the power, pull out the power plug, and ask your dealer to repair. Do not try to repair it by yourself. It is dangerous.

■ Do not touch the machine with wet hands.

- Touching the machine with wet hands may cause an electric shock.

■ Do not touch the power plug during electrical storms.

- Lightning may cause an electric shock.

■ Ground the machine with the attached electric cord when connecting it to the utility outlet.

- Using a cord other than the one supplied for grounding may cause an electric shock when the machine fails.

■ **Do not put your head or yourself into the packaging bag.**

- Do not play with the packaging bag. You may suffocate yourself.
- Give close attention to small children who may want to play with the packaging bag.

■ **Do not use the machine while it has a fault.**

- Do not use the machine while it has a fault, as this may cause a fire or electric shock.
- Immediately turn off the power, pull out the power plug, and ask your dealer to repair. Do not try to repair it by yourself. It is dangerous.

■ **Do not use the laminator when cards are jammed inside.**

- Cards may not be discharged correctly such as when the laminator setting for the card is inappropriate. Stop using and remove the jammed cards immediately. Otherwise, you may have problems removing the cards, and fire or electric shock may also occur as a result.

CAUTION

■ **Pull out the power plug before cleaning the machine.**

- This is for preventing electric shocks.

■ **Pull out the power plug when you won't use the machine for a prolonged period of time to assure safety.**

- Remove the power plug from the outlet for safety when you won't use the machine for a long time.

■ **Do not move the machine with the power cable and other electric cables connected.**

- The cables may be damaged while being moved, which may cause a fire or electric shock.
- You may stumble over the cable and get injured.

■ **Do not move the machine with objects placed on it.**

- They may fall on you and hurt you.

■ **Do not put heavy objects on the machine.**

- They may fall on you and hurt you.

■ **Do not block the vents.**

- Heat generated inside the machine cannot escape, which may cause a fire.

■ **Do not rest your body on the machine, or leave it suspended above the ground.**

- The machine may drop, causing damage or injury. Pay particular attention when there are young children around.

■ **Inspection**

- Ask your dealer or a qualified person to inspect the machine, typically once every two to three years. Operating the machine with dusts piling on the components for a prolonged period of time may cause a fire or a malfunction of the machine. It will be particularly effective to inspect the machine before wet rainy season. Consult your dealer on the costs of inspection.

■ **Do not place the machine in the following locations.**

Doing so may cause fire or electric shock.

- Places that are highly humid or dusty.
- Places that are exposed to oily smoke or steam, such as near a cooking table or humidifier.
- Places near a heating equipment.
- Places that are subject to water droplet condensation, such as beside a window.

Also, placing it at a place that is exposed to direct sunlight may result in deterioration of the cabinet.

■ **Hold the body of the power plug when pulling it out.**

- Do not pull out the plug by holding the cable. The cable may be broken or damaged which may in turn cause a fire or electric shock.

■ **Do not touch the power plug with a wet hand**

- You may get an electric shock.

■ **Do not lay the power cable near the heating equipment.**

- The covering of the cable will melt due to heat from such equipment, which may cause a fire or electric shock.

■ **The heat rollers and adjacent areas become hot during operation.**

- When pulling out the film cassette or removing a jammed card, make sure that you do not touch the heating roller and its surroundings.
- Wait until the heat rollers get cooled down to prevent burns.

■ **Be sure to use the power cord supplied with this laminator.**

- Using a power cord that is of a different voltage or a damaged power cord will result in fire or electric shock.

■ **The power cord should be used only with this laminator.**

- Do not use the power cord with products other than this laminator. Doing so may result in fire or electric shock.

■ **Hold the laminator at bottom of the two sides (handle) when installing or moving the laminator.**

- Carrying the laminator by its corners or front and back may result in catching your fingers in between the laminator and the floor or table.

■ **Do not hold the rear filter cover when installing or moving the laminator.**

- The filter cover may be damaged or detached from the laminator, causing the laminator to fall off and resulting in injuries.

About this Manual

Symbols Used in this Manual

Cautions : States precautions to be taken during operation.

Memo : States restrictions on the functions or use of this equipment. for reference purposes.

 : Indicates the page numbers or items to refer to.

Contents of this Manual

- The copyright of this manual belongs to our company. Reprint and duplicate of this manual in part or full without the prior consent of our company is strictly prohibited.
- Designs, specifications, or other details described in this manual may be modified for improvement without prior notice.

Precautions During Use

Please read through all the following items before using the laminator.

Laminator Installation

- When you are not printing cards, it is recommended that you turn off the power, and use a cover that is large enough to cover up the card printer and laminator units.
- Avoid installing at the following locations as doing so may have adverse effects on this unit.
 - Carpeted room.
 - Places with a busy flow of people.
 - Places where paper (corrugated boards, etc.) is handled or stored.
 - Places near photocopiers.
 - Places exposed to direct sunlight or near a heating equipment (such as a stove).
 - Inclined or unstable surfaces.
 - Places exposed directly to cold air, such as near an air-conditioner outlet, or places subject to high temperatures.
- During installation, make sure that there is sufficient space around the laminator. (Allow a clearance of at least 20 cm between the sides of the laminator and the wall. Allow a clearance of at least 10 cm between the rear of the laminator and the wall.)
- Observe the following when installing or moving the laminator.
 - Make sure to turn off the power before moving the laminator.
 - Carry the laminator at the bottom of the two sides (handle) to prevent your hands or fingers from being caught under the unit.
 - The filter cover is detachable for replacing the fan filter. When you are moving the laminator, do not hold it at the filter cover.

Films

■ Handling procedures

Pay attention to the following points when handling films.

- Do not touch the film surface with your hand. Doing so may result in poor adhesion.
- Foreign objects attached to the surface of the film may result in poor adhesion. Load the film in a clean environment.
- If the film is left unattended for a prolonged period of time with the laminator in the [Ready] state, the heat from the heater may cause the film to change color. When this unit is not in use, turn off the power, or switch it to the card printer's "Power-saving mode".
- When replacing films with one that has been stored under a low temperature, store it at the operating ambient temperature of the laminator for at least one hour before using. Otherwise, condensation may occur, causing poor adhesion or malfunction.

■ Storage environment

- Temperature: 5 °C to 25 °C
- Relative humidity: 50 % and below

■ Storage location

Do not store in the following locations.

- Places exposed to direct sunlight.
- Places with a high temperature and humidity.
- Places near organic solvents or diazo copiers.

■ Storage period

Use it as soon as possible after opening.

Cards

■ Compliant cards

Compliant with ISO 7810 ID-1

For details on the handling and storage procedures of cards, refer to the manual of the card printer.

Cautions:

- Reimbursement will not be done for poor adhesion or card warpage. For more information about the card, please consult our authorized dealers and evaluate the settings.

Capability of this Unit

- This laminator selects the side of the card to be laminated by the presence of the film cassette. Refer to the following table and load the film cassette to the side of the card to be laminated.

Side to Be Laminated	Film Cassette Status	
	Top side film cassette	Bottom side film cassette
Double-sided lamination	Load	Load
Top side lamination	Load	Remove
Bottom side lamination	Remove	Load

Cautions:

- An error will occur if a film cassette that is not loaded with laminate film is attached to the side that is not to be laminated. Remove the film cassette from the side that is not to be laminated.
- For double-sided lamination, ensure that both the top side and bottom side film cassettes are attached. The absence of film cassette on either side will result in single-sided lamination.
- For double-sided lamination, use the same type of laminate film for the top side and bottom side. Using different types of laminate film may result in card jam or error.
- Please store the removed film cassette properly.

Name and Functions of Parts

Front

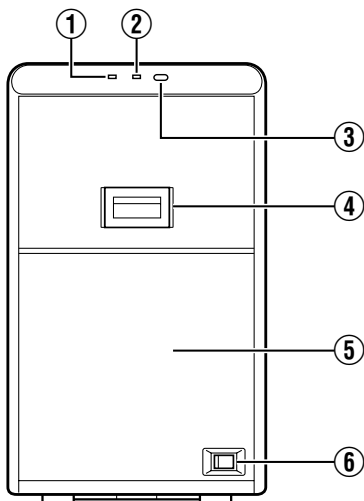

① LED display (red)

- Blinks or lights up in red, and combines with the ② LED display (blue) to indicate the status of the laminator. (☞ page 15 “Laminator Status, LED Display and Card Printer’s Operation Panel Display”)

② LED display (blue)

- Blinks or lights up in blue, and combines with the ① LED display (red) to indicate the status of the laminator. (☞ page 15 “Laminator Status, LED Display and Card Printer’s Operation Panel Display”)

③ Operation button

- Pressing this button when the laminate film is loaded will reset the laminator settings.
- When no film cassette is loaded, pressing the button for two seconds or longer starts the cleaning operation. (The cleaning operation does not start if the heating roller is still hot.)

④ Sliding knob

- Opens/closes the laminator door.

⑤ Laminator door

- Closing the door when the laminate film is loaded will reset the laminator settings.
- This door can be locked by operating in conjunction with the card printer unit through the security lock function.

⑥ Power switch

- Turns the power On/Off.
- **I** represents “On” and **O** represents “Off”.

Rear

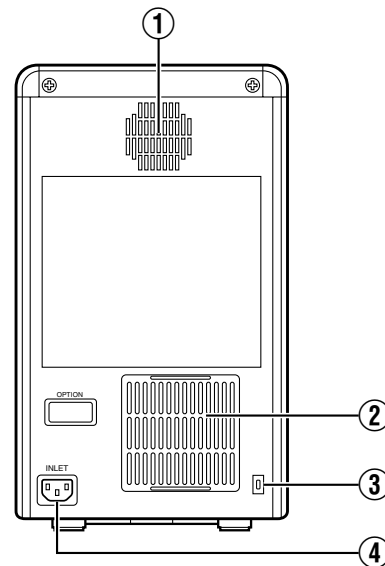

① Exhaust fan

- Discharges heat accumulated inside the laminator unit.

② Air suction fan opening

- Air inlet of the internal cooling fan.

③ Security slot

- An anti-theft device that supports Kensington locks can be attached.

④ AC inlet

- For connecting the power cord.

Before Use

Right

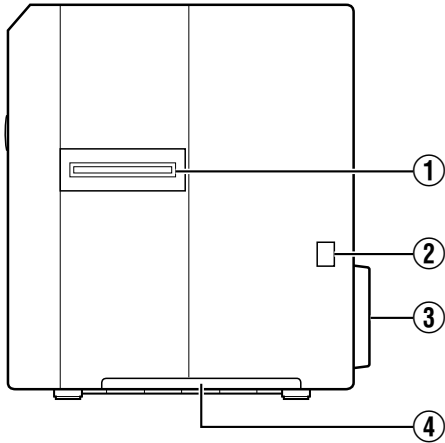

- ① **Card feed port**
 - Feeds the printed card from the card printer that is connected to the laminator.
- ② **Infrared window**
 - Sends or receives data via infrared communication by connecting with the card printer.
- ③ **Filter cover**
 - Remove when you want to exchange the filter.
 - When moving the laminator, do not carry it at the filter cover.
- ④ **Handle**
 - Hold this area when moving the laminator.

Left

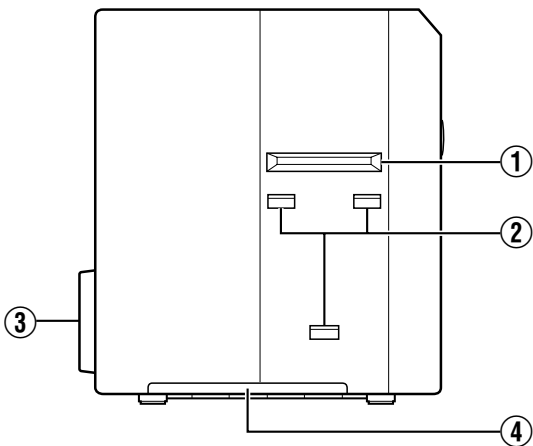

- ① **Card outlet**
 - Discharges the cards.
- ② **Card stacker attachment slot**
 - For attaching the card stacker supplied with the card printer.
- ③ **Filter cover**
 - Remove when you want to exchange the filter.
 - When moving the laminator, do not carry it at the filter cover.
- ④ **Handle**
 - Hold this area when moving the laminator.

When Laminator Door is Open

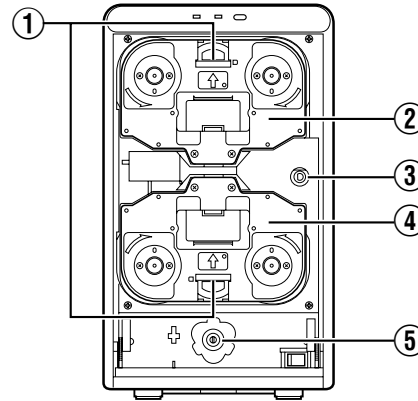

- ① **Cassette buttons**
 - Press the buttons to remove the film cassette.
- ② **Top side film cassette (orange)**
 - For attaching the laminate film.
- ③ **Jog dial attachment slot**
 - For discharging the card during a card jam by attaching the jog dial supplied with the card printer to the card feed roller and turning it.
- ④ **Bottom side film cassette (yellowish-green)**
 - For attaching the laminate film.
- ⑤ **Jog dial attachment slot**
 - Enables attachment of a supplied jog dial to the card printer.

Film Cassette

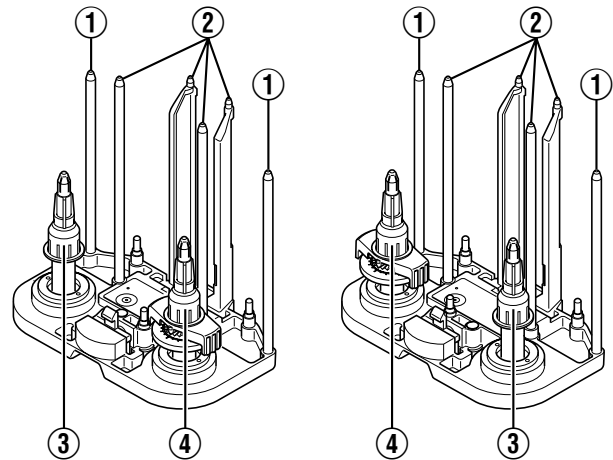

- ① **Guide shaft**
 - Provides guide to the position for attaching the film cassette.
- ② **Film Guides**
 - When attaching the laminate film, unwind it along the shafts.
- ③ **Bobbin holder**
 - For securing the take-up side of the laminate film.
- ④ **Bobbin holder (patch position adjustment mechanism attached)**
 - For securing the supply side of the laminate film.
 - It can also be used to adjust the patch position in the front back direction.

Internal Mechanism Diagram

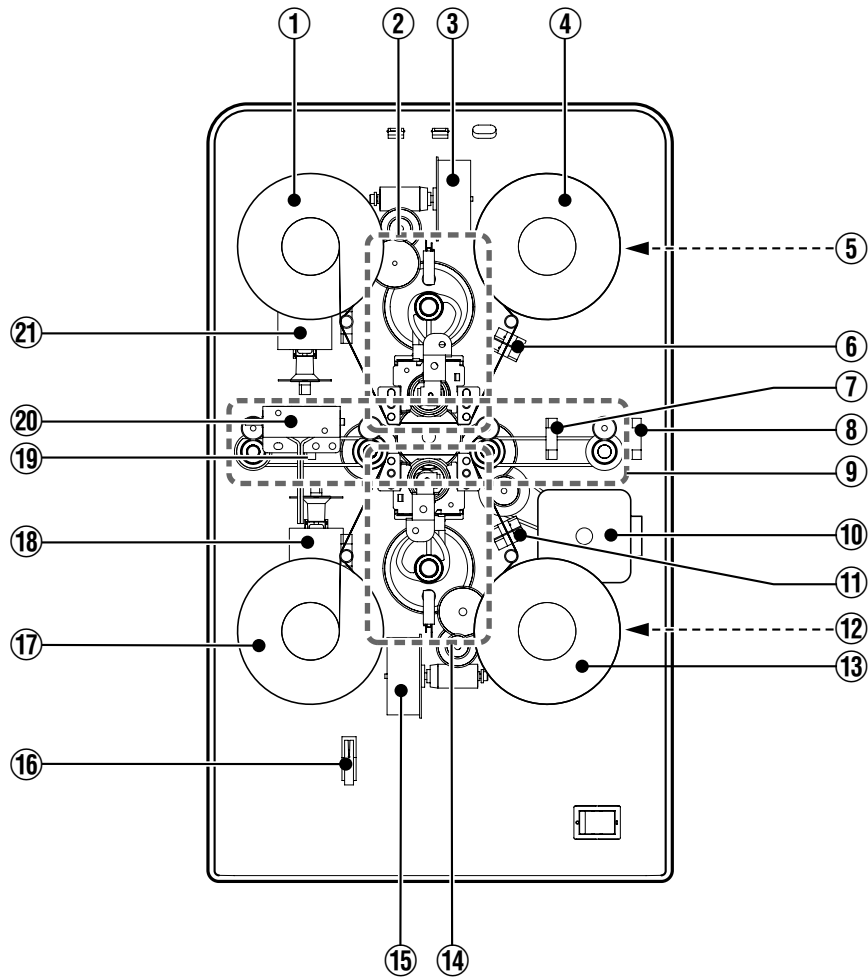

- | | |
|---|--|
| ① Top take-up side laminate film | ⑫ Bottom side laminate film supply motor |
| ② Top side laminate heater pressure mechanism | ⑬ Bottom supply side laminate film |
| ③ Top side laminate pressure motor | ⑭ Bottom side laminate heater pressure mechanism |
| ④ Top supply side laminate film | ⑮ Bottom side laminate pressure motor |
| ⑤ Top side laminate film supply motor | ⑯ Interlock switch |
| ⑥ Top side laminate film position sensor | ⑰ Bottom take-up side laminate film |
| ⑦ Card lamination position sensor | ⑱ Bottom side laminate film take-up motor |
| ⑧ Inlet sensor | ⑲ Card discharge sensor |
| ⑨ Card feeder unit | ⑳ Security lock solenoid |
| ⑩ Card feed motor | ㉑ Top side laminate film take-up motor |
| ⑪ Bottom side laminate film position sensor | |

Specifications

Main Specifications

Item	Description
Recording system	DC heat roller system
Transfer time	Approx. 22 sec. to 38 sec. (Time varies according to the setting.)
Operating environment conditions	Temperature: 15 °C to 28 °C Humidity: 35 % to 60 % (no condensation)
Storage environment conditions	<Laminator unit> Temperature: -15 °C to 55 °C Humidity: 20 % to 80 % <Laminate film> Temperature: 5 °C to 25 °C Humidity 50 % and below
Power supply	AC 100 V - 120 V, 50 Hz/60 Hz AC 220 V - 240 V, 50 Hz/60 Hz
Current consumption	3.5 A (100 V system) 1.6 A (200 V system)
Mass	Approx. 9.5 kg
Dimensions	210 mm × 360 mm × 330 mm (W x H x D)

Outline Dimensional Drawing

■ Front View

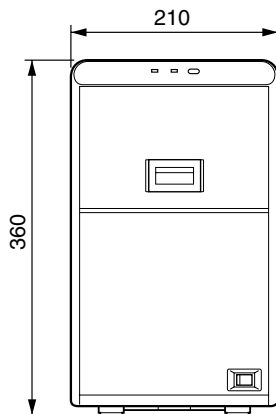

■ Side View

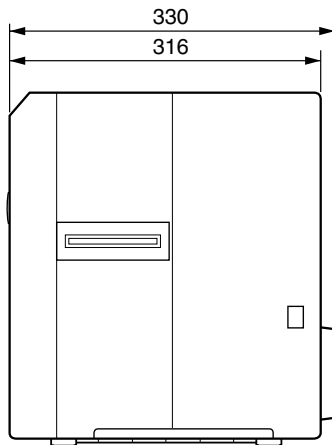

* The specifications and appearance of this product may be modified for improvement without prior notice.

Accessories/Products Sold Separately

Accessories

Please check to ensure that the laminator accessories are in place when unpacking the product package.

- Power Cord (2 m) x 2

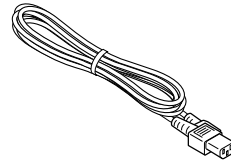

For AC100V-120V Type
(North America)

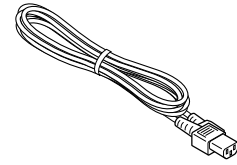

For AC220V-240V Type
(Europe)

- Instruction Manual x 1

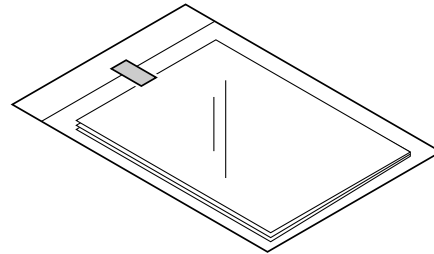

- Unit Connection Adapter x 1

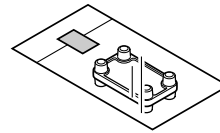

- Cleaning Card x 1

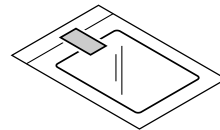

- Bobbin x 2

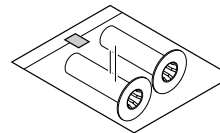

Products Sold Separately

To purchase these items, please consult our authorized dealers.

- 0.6 mil patch film
- 1 mil patch film
- Overlay film
- Cleaning Kit, Model: CX210-CKIT2
Magnetic Head Cleaning Card (5 Pcs),
Cotton Swab (5 Large and 5 Small), Cleaning Wipes (1 Box)
- Cleaning Card, Model: CX210-CC1
10 Pcs/Set

Installation and Connection

Installation Location

- Ventilation holes for the cooling fan are located at the rear of the laminator as well as the side and rear of the card printer.
- Allow a clearance of at least 20 cm between the sides of the laminator and the wall.

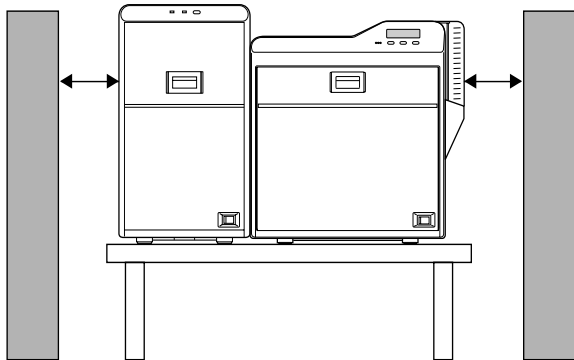

- Allow a clearance of at least 10 cm between the rear of the laminator and the wall.

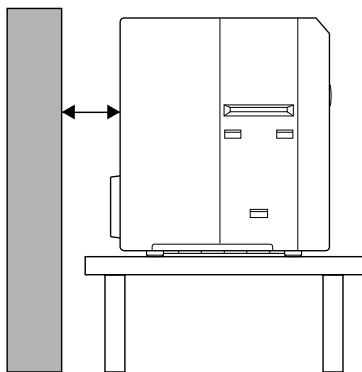

- Do not place any object on the laminator.

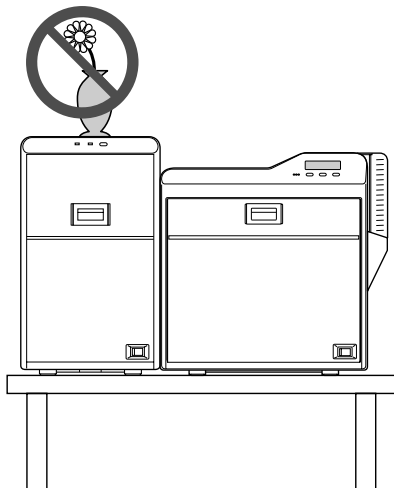

Card Printer Connection

- 1 Fit the card printer to the supplied unit connection adapter

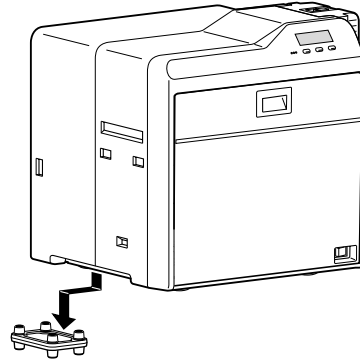

- 2 Fit the laminator to the supplied unit connection adapter

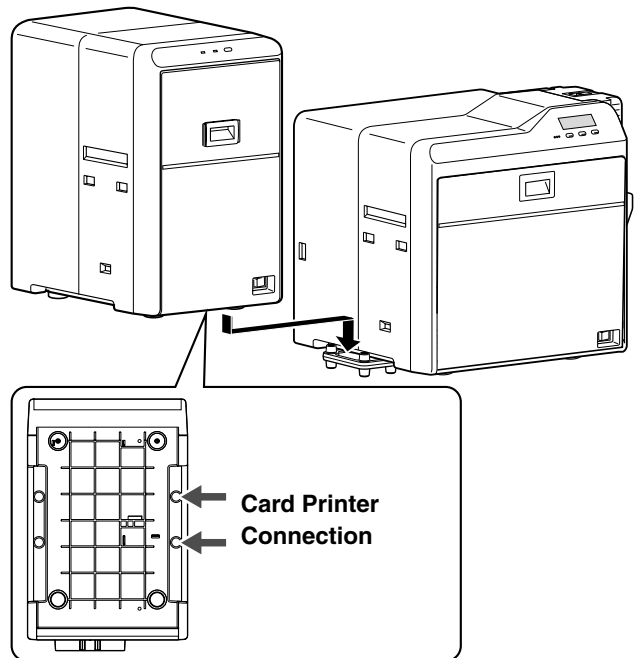

Cautions:

- Do not hold the rear filter cover when installing or moving the laminator. The filter cover may be damaged or detached from the laminator, causing the laminator to fall off and resulting in injuries.
- Make sure that you connect the units on a flat and firm surface.
- Insert the unit connection adapter firmly into the card printer connection. Cards cannot be fed if there is a difference in level.
- After installation, if you need to remove the laminator from the card printer, turn off the power of the card printer.

Card Stacker

- 1 Hook the tab of the card stacker that is supplied with the card printer to the card stacker attachment slot

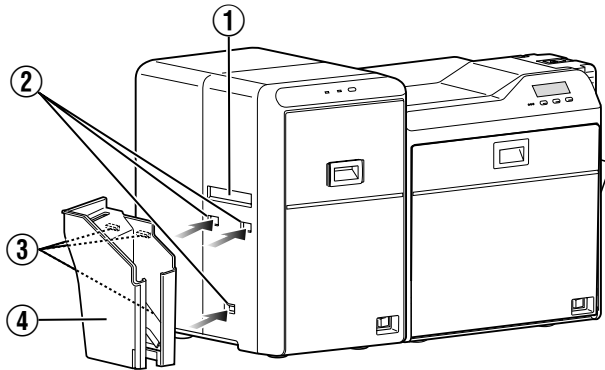

- ① Card outlet
- ② Card stacker attachment slot
- ③ Tab
- ④ Card stacker

Power Cord Connection

- 1 Insert the power cord (supplied) to the AC inlet at the rear of the laminator
- 2 Plug the power cord (supplied) into an outlet

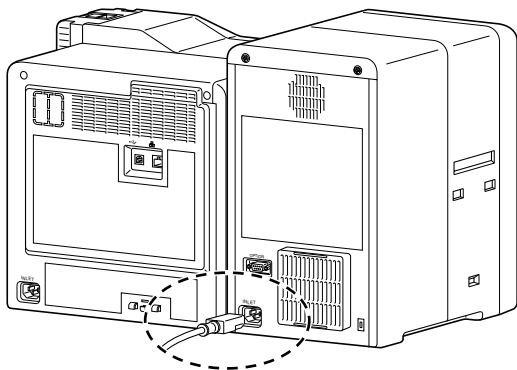

Cautions:

- Make sure that the power outlet is grounded and used as a dedicated power source for the laminator. Make sure that the power cord is inserted directly into the outlet, and do not share with other devices.

Memo:

- Make use of an AVR (automatic voltage regulator) to prevent any fluctuation in voltage. Alternatively, an uninterruptible power supply is recommended in case momentary power outage occurs.

Setting Laminate Film

- Attach a patch film or overlay film on the film cassette.
- The film type is set to patch film by default. When using overlay film for the first time after purchasing the laminator, turn on the laminator and the card printer and change [Film Type] of the laminator to [Overlay] on the status monitor before removing the cassette to load the film.
- This laminator selects the side of the card to be laminated by the presence of the film cassette. Load the film cassette to the side of the card to be laminated.

Cautions:

- If the security lock of the card printer is on, deactivate it. After work is complete, activate the security lock again. For details on locking/unlocking the security lock, refer to the manual of the card printer.
- Stand the film cassette on a flat surface. Avoid doing so on a floor as dust attached to the film may cause poor adhesion or malfunction.
- A film cassette that has laminate film attached on it is heavy. Hold the film cassette with both hands to avoid dropping when working with it.
- If the laminate film is attached in the wrong direction, film detection error or lamination defects may occur. Attach the laminate film in the right direction.
- Match the loaded laminate film with the [Film Type] setting. If the laminate film and the setting do not coincide, film detection error occurs after the laminate film has been forwarded for a certain length.
- In the case of single-sided lamination, an error will occur if a film cassette that is not loaded with laminate film is attached to the side that is not to be laminated. Remove the film cassette from the side that is not to be laminated.
- For double-sided lamination, ensure that both the top side and bottom side film cassettes are attached. The absence of film cassette on either side will result in single-sided lamination.
- For double-sided lamination, use the same type of laminate film for the top side and bottom side. Using different types of laminate film may result in card jam or error.

- 1 Open the laminator door

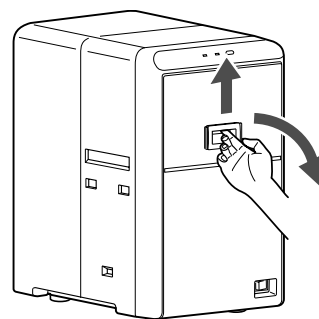

- 2** Press and hold down the cassette button, and pull out the film cassette

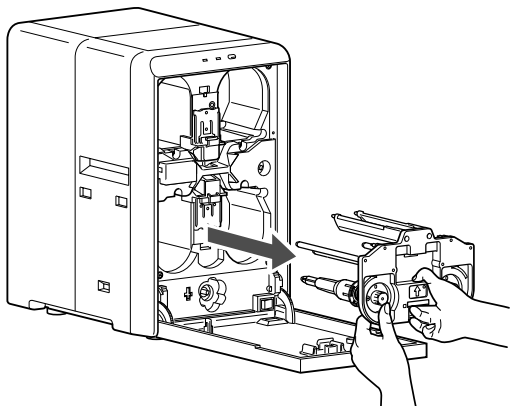
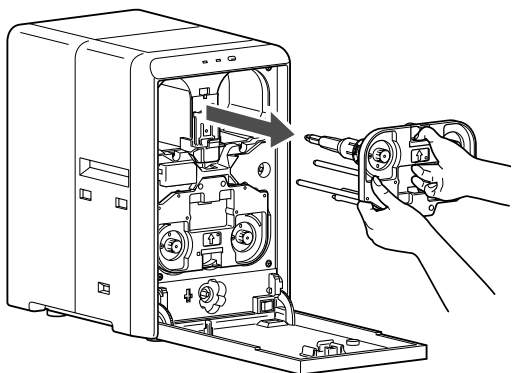

- 3** Attach the tip of the new laminate film to the bobbin

- ① Place the new laminate film and the take-up bobbin side by side on a clean and flat platform.
- ② Attach the tip of the new laminate film to the take-up bobbin using the fixing tape.

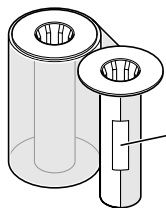

Use the fixing tape after peeling off the adhesive label of the laminate film.

Cautions:

- Attach the laminate film to the take-up bobbin such that they are parallel to each other. Otherwise, it may result in poor adhesion or cause film detection errors.

- 4** Install the new laminate film on the film cassette

- Install while referring to the indication on the label of the cassette.

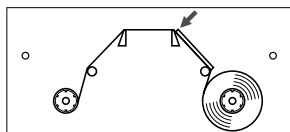

Top Side Film Cassette

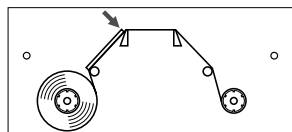

Bottom Side Film Cassette

- ① Insert the supply side of the film into the bobbin holders (patch position adjustment mechanism attached).
- ② Unwind the laminate film along the film guides, and insert the take-up side into the bobbin holders.

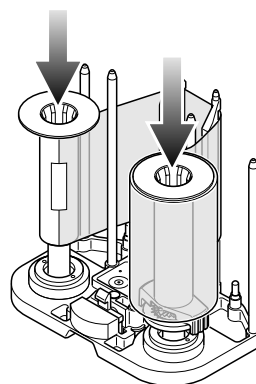

Top Side Film Cassette

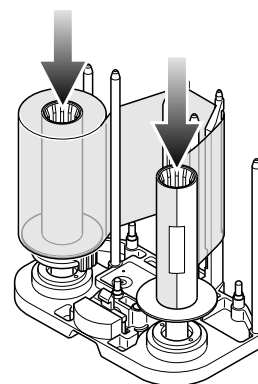

Bottom Side Film Cassette

- ③ Wind the film twice around the take-up side.

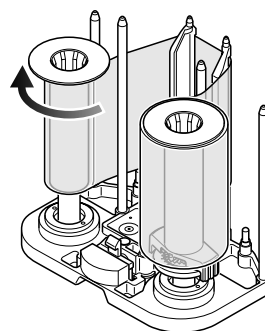

Top Side Film Cassette

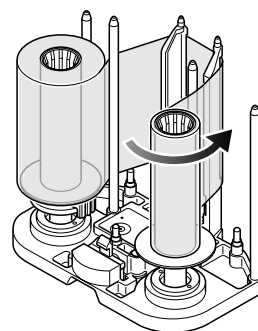

Bottom Side Film Cassette

- 5** Remove any slack in the laminate film

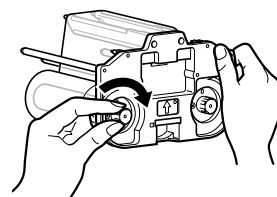
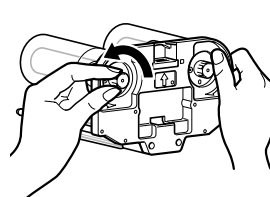

- 6** Insert the film cassette all the way in along the guide rail until a “click” sound is heard, and close the laminator door

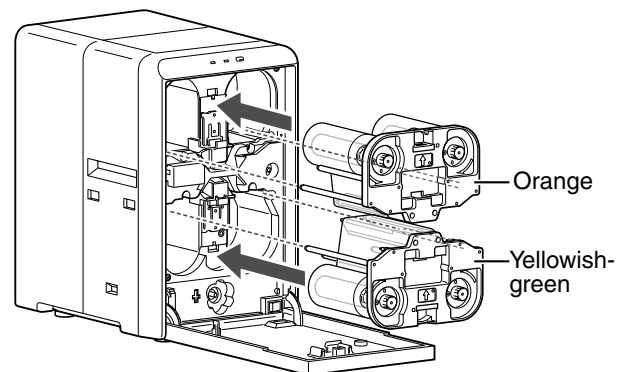

Cautions:

- Make sure to insert the film cassette all the way in until a “click” sound is heard. Failure to do so may result in defective patch or card jam.
- If the film cassette is inserted upside down, it cannot be inserted all the way in and the cassette button does not lock in place. Also, you will not be able to close the laminator door.

Operation Panel

- The status display of the laminator is displayed on the operation panel of the card printer as well as the status monitor of the computer that is connected to the card printer.
- The status is indicated on the laminator unit using a combination of solid and blinking LED displays in red and blue colors.

■ Card printer operation panel

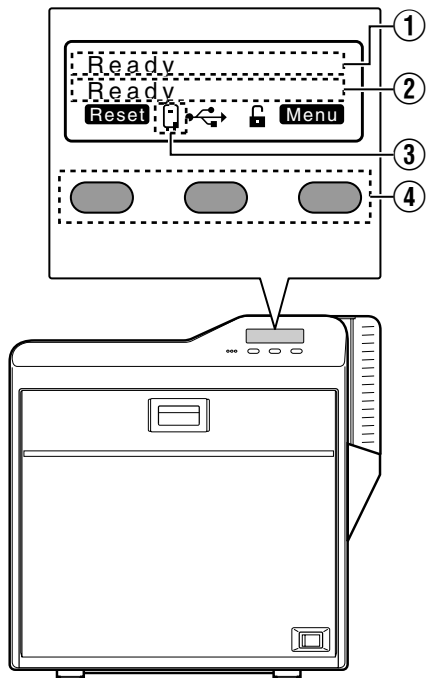

- ① Printer status display**
 - Displays the status of the card printer.
- ② Laminator status display**
 - Displays the status of the laminator when the display mode of the card printer is set to [Laminator State].
(☞ page 15 "Setting Procedures for Laminator Status Display")
- ③ Status icon display**
 - A laminator icon is displayed once the card printer recognizes the laminator.
- ④ Operation button**
 - For selecting a button function displayed on the operation panel.

■ Laminator operation panel

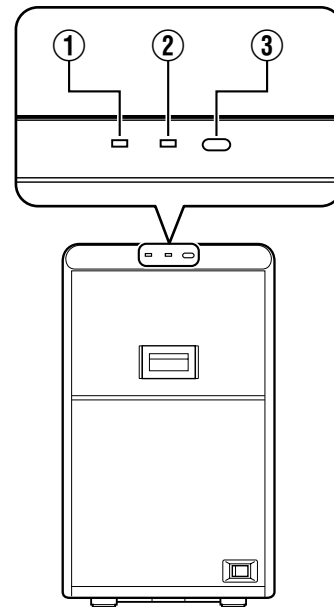

- ① LED display (red)**
 - Indicates an error when only the red light is lit or blinking.
- ② LED display (blue)**
 - Indicates that the laminator is functioning normally when only the blue light is lit or blinking.
- ③ Operation button**
 - Pressing this button when the film is loaded will reset the laminator settings.
 - When no film cassette is loaded on the top and bottom sides, pressing the button for two seconds or longer starts the cleaning operation. (The cleaning operation does not start if the heating roller is still hot.)
(☞ page 25 "Card Feed Roller/Heating Roller")

Laminator Status, LED Display and Card Printer's Operation Panel Display

Laminator Status	LED display (red)	LED display (blue)	Card Printer Operation Panel Display	Description
Initializing	Off	Blinking (Slow)	Initializing..	Initializing in progress
Preheating			Preheating..	Adjusts the heating roller to the preset temperature
Low temperature standby mode			Standby	In HR Control mode
Power-saving mode			Sleeping..	Low power consumption standby mode. Operates in conjunction with the card printer settings.
Ready	Off	On	Ready	Ready for laminating operations.
Laminating	Off	Blinking (Fast)	Laminating..	Laminating in progress
Error mode	Blinking (Slow)	Off	Error message	Errors that does not require reboot of the power, such as insufficient film, film error, cassette not loaded, and card jams. (☞ page 38 "List of Error Codes")
	Blinking (Fast)	Off	Error message	Errors that require reboot of the power (☞ page 38 "List of Error Codes")
Roller cleaning in progress	Blinking (Slow)	Blinking (Slow)	Cleaning..	Awaiting insertion of the cleaning card, or cleaning is in progress. Returns to the original state if a cleaning card is not inserted after a specific time interval.
Download mode	On	On	Download	Awaiting download data, or process has ended
Downloading	Blinking (Fast)	Blinking (Fast)	Downloading..	Downloading data. Memo: The blinking speed is faster than that when laminating is in progress.

Setting Procedures for Laminator Status Display

- You can display the laminator status on the operation panel of the card printer.

1 Press **Menu**

- Enter the setting mode.

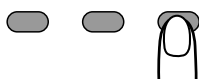
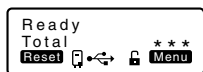

2 Press **Next** to set to [Setting]

- Pressing it each time displays the next setting item.

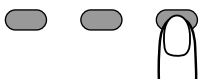

3 Press **Enter**

- A [Display] message appears.



4 Press **Enter**

- A [Mode] message appears.



5 Press **Change**

- Enter the settings change mode.

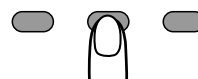
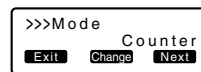

6 Press **Down Arrow** and select [Laminator State]

7 Press **Left Arrow** to confirm the setting

- Pressing **Left Arrow** confirms the setting and returns you to the previous screen.

8 Press **Exit** to exit the setting mode

- Pressing it each time displays the setting item of the next higher level.

Checking the Laminator Settings

- Settings can be viewed on the card printer's operation panel.
- Settings can be changed on the status monitor of the computer that is connected to the card printer.
(page 20 "Status Monitor Settings")

1 Press **Menu**

- Enter the setting mode.

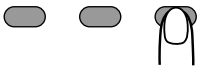
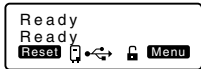

2 Press **Next** to set to [Laminator]

- Pressing it each time displays the next setting item.



3 Press **Enter**

- A [Mode] message appears.
- Pressing **Next** each time displays the next setting item and its current setting.



4 After checking is complete press **Exit** to exit the setting mode

- Pressing it each time displays the setting item of the next higher level.

Settings

Laminator

- **Mode: Laminate, Pass**
Set to [Laminate] to perform laminating.
Set to [Pass] if you do not want to laminate.
- **Cassette: None, Top, Bottom, Both**
The load status for the film cassette appears.
- **Film-T: Patch, Overlay**
For selecting the film to be used for the top side.
- **Film-B: Patch, Overlay**
For selecting the film to be used for the bottom side.
- **Film-T Pos:**
-7, -6, -5, -4, -3, -2, -1, 0, 1, 2, 3, 4, 5, 6, 7
For setting the patch position for the moving direction of the top side.
- **Film-B Pos:**
-7, -6, -5, -4, -3, -2, -1, 0, 1, 2, 3, 4, 5, 6, 7
For setting the patch position for the moving direction of the bottom side.
- **HR-T Temp:**
90 degC to 180 degC (in increments of 5 degC)
For setting the top side heating roller temperature.
(The temperature may be 185 degC or higher depending on the firmware version of the card printer. However, in this case, the temperature for the heating roller remains at 180 degC.)
- **HR-B Temp:**
90 degC to 180 degC (in increments of 5 degC)
For setting the bottom side heating roller temperature.
(The temperature may be 185 degC or higher depending on the firmware version of the card printer. However, in this case, the temperature for the heating roller remains at 180 degC.)
- **Speed: 3.0 mm/s to 12.0 mm/s**
(in increments of 0.5 mm/s)
For setting the card feed speed during lamination.
- **Cooling Time: 0sec, 5sec, 7sec, 10sec, 15sec, 20sec, 30sec**
For setting the standby time for cooling down the card immediately before lamination starts.
- **HR Control: Off, On**
For setting the low temperature standby mode. This setting works simultaneously with the card printer setting. For setting whether to standby the laminator by lowering the heating roller temperature if cards are not printed for 30 minutes or longer.
This is always set to [On] automatically when overlay film is selected.
(Regardless of the setting, turn off the heating roller and standby the laminator if you will not be performing card printing for a long time.)
- **Count**
Displays the number of laminations performed after the last roller cleaning. This number is reset to 0 each time roller cleaning is performed.

■ Factory Settings

Item	Factory Settings
Mode	Laminate
Film-T	Patch
Film-B	Patch
Film-T Pos	0
Film-B Pos	0
HR-T Temp	140 degC
HR-B Temp	140 degC
Speed	7.0 mm/s
Cooling Time	0sec
Count	0

Initializing

- Performing the operations below will reset the laminator settings. Thereafter, when the heating roller is adjusted to the preset temperature, a [Ready] message will be displayed and laminating can be performed.

Turning On the Power

- Turning on the power when the laminate film is loaded will reset the laminator settings.

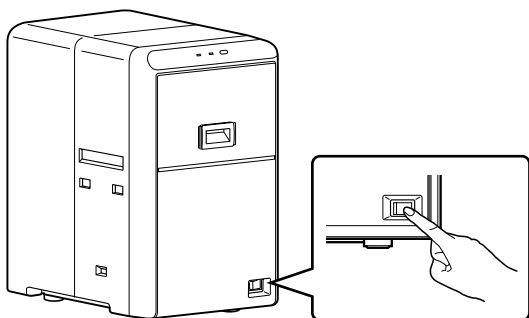

Closing the Laminator Door

- Closing the laminator door when the laminate film is loaded will reset the laminator settings.
- Loading a patch film will forward the laminate film by one image and reset the laminator settings.

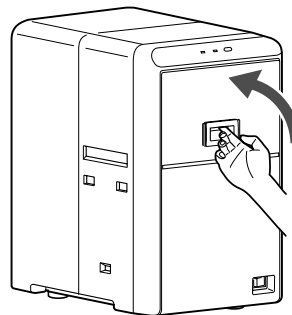

Cautions:

- If the loading statuses of the top side and bottom side film cassettes change when opening and closing the laminator door, initialization may not be performed when the laminator door is closed. In this case, press the operation button to initialize.

Pressing the Operation Button

- Pressing the operation button when the laminate film is loaded will reset the laminator settings.
- Loading a patch film will forward the laminate film by one image and reset the laminator settings.

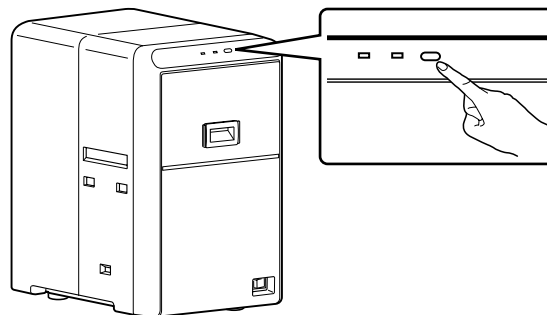

Operating the Laminator

Turning On the Power

- 1 Check to ensure that the card printer and laminator are properly connected
- 2 Turn on the power of the laminator

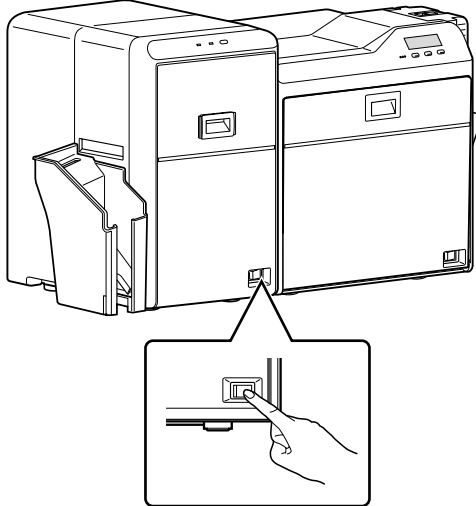

- 3 Turn on the power of the card printer

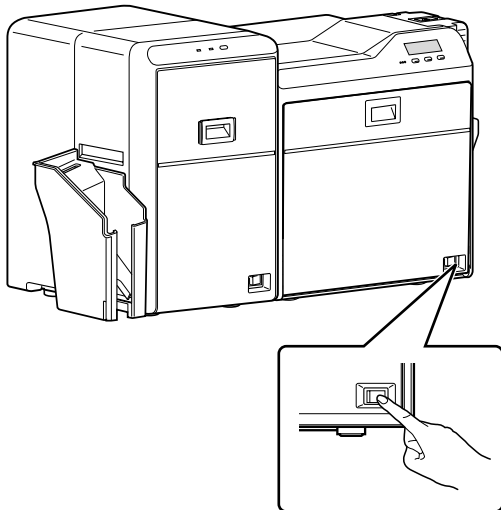

Turning Off the Power

- 1 Turn off the power of the card printer

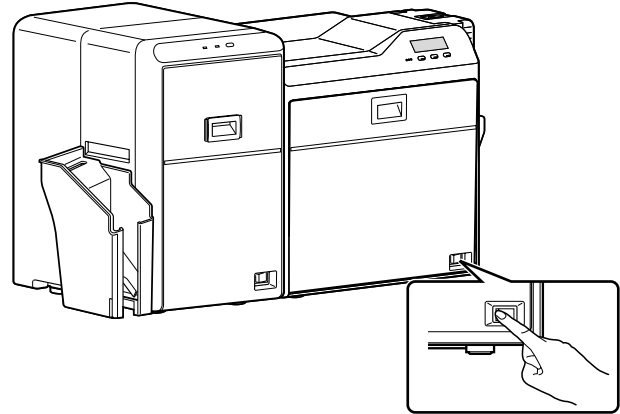

- 2 Turn off the power of the laminator

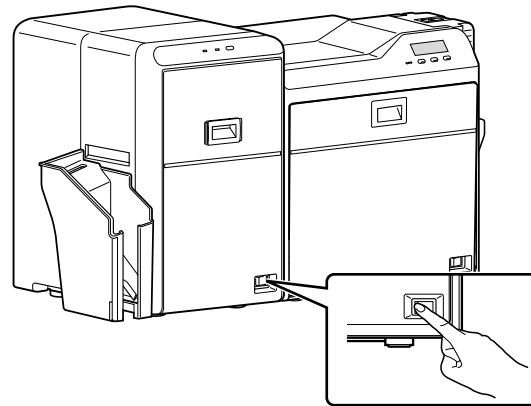

- Turn on the power again only after both LED displays of the laminator have been turned off.

Cautions:

- Turn on the power for the laminator first. If the power for the card printer is turned on first, the card printer may not recognize the laminator.
- Do not interrupt the laminator when laminating is in progress. Doing so may cause cards to adhere to the interior of the laminator, thus causing it to malfunction. Make sure to observe the following.
 - Do not open the laminator door
 - Do not turn off the power
 - Do not unplug the power cord
- Check the laminator settings before printing.

Firmware Update

- Setting the laminator and card printer to download mode enables you to update the firmware for the laminator by using a PC through card printer connection.

- 1 Press and hold down the operation button, and turn on the power at the same time
 - Both the LED displays are lit.

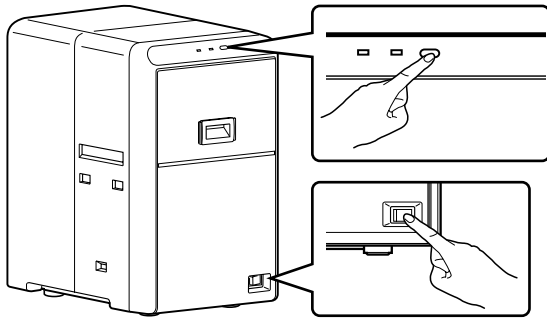

- 2 Turn on the power of the card printer

- 3 Press **Menu**
 - Enter the setting mode.

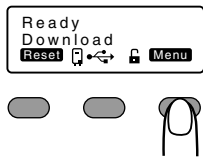

- 4 Press **Next** to set to [Download]
 - Pressing the [Next] button each time displays the next screen.

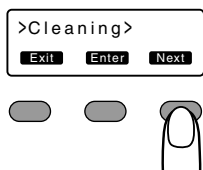

- 5 Press **Enter**
 - A [Download Ready] message appears, indicating that the card printer is ready to download data from the computer.

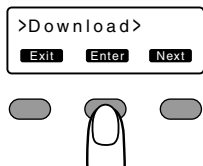

- 6 Data download from the computer starts
 - A [Downloading..] message appears.

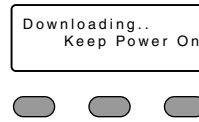

Cautions:

- It takes time to download the data.
- Do not turn off the power during data download from the computer. Doing so may damage the laminator firmware and cause malfunction.

- A [Download Ready] message appears when data download from the computer is complete.



- 7 Press **Exit** when [Download Ready] is displayed
- 8 Turn off the power for the card printer when [Please Power Off] is displayed
- 9 Turn off the power of the laminator
 - The firmware is updated after the power is turned on again.

■ When download fails and the laminator cannot start up

- Update the firmware again.

Status Monitor Settings

What is status monitor?

- Status Monitor is a software that displays the status for the card printer and laminator, and enables you to adjust the settings for the card printer and laminator.
- Start the status monitor by using a computer that is connected to the card printer. For details on starting the status monitor, refer to the manual of the card printer.

[Printer Status] Tab Sheet

- Displays the status of the laminator.

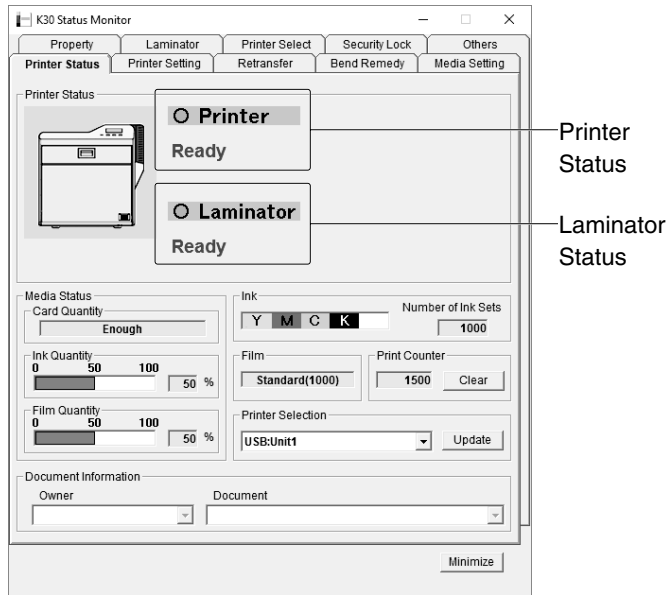

- Failure has occurred. The error code and description of the failure are displayed. In the example below, “05000059” is the error code. For more details, refer to “List of Error Codes”.

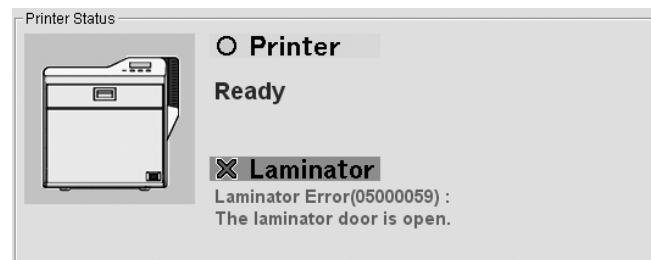

List of Status Display Messages

Status Display Message	Description
Laminator is not found.	The power of the laminator is not turned on, or the laminator is not properly connected to the card printer.
Ready	The laminator is in the ready mode.
Initializing	Laminator initializing in progress.
Cleaning	Roller cleaning of the laminator is in progress.
Preheating	Preheating of the laminator's heating roller is in progress. The laminator switches to Ready mode upon reaching the preset temperature.
Laminating	Card laminating of the laminator is in progress. After laminating is complete, the laminator returns to the Ready mode.
Power Saving	The laminator is in the Power Saving mode, which helps to reduce power consumption. To exit the Power Saving mode, reset using the operation panel of the card printer.
Download Mode	The laminator is in the download mode.
Low Power Mode	Standby state with the heater temperature lowered when cards are not printed for a specific time interval.

Laminator Status

- Ready mode. The laminator is ready to start printing.

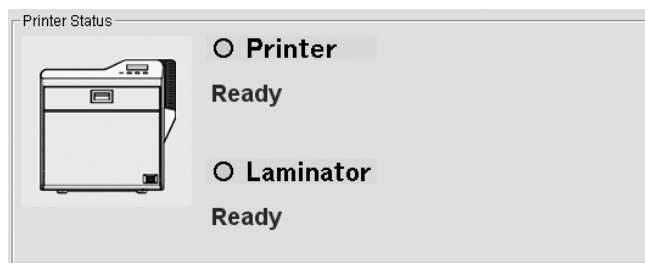

- The laminator is busy.

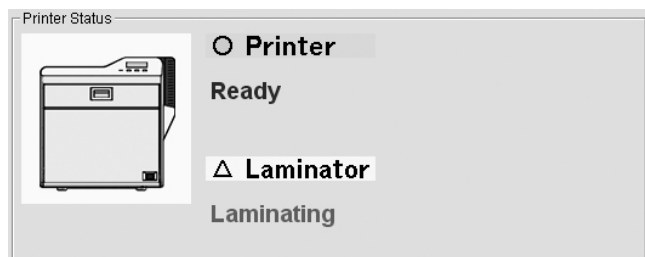

■ List of Error Codes

Error Code	Error Display Message	Action
05000050	Failure occurred during card loading.	<ul style="list-style-type: none"> ● Check to ensure that the laminator is properly connected to the card printer. (☞ page 11 “Card Printer Connection”) ● Remove the card. (☞ page 32 “Card Jam”)
05000051	Card jam near the card feed roller.	<ul style="list-style-type: none"> ● The temperature of the heating roller may be too high, or the card transfer speed may be too slow. For details on adjusting optimum settings, please consult our authorized dealers. ● Remove the jammed card. (☞ page 32 “Card Jam”)
05000052	Card jam near the card outlet.	
05000053	Top side film has run out.	<ul style="list-style-type: none"> ● Replace the laminate film with a new one.
05000054	Bottom side film has run out.	
05000055	Top side film is broken or is not detected.	<ul style="list-style-type: none"> ● Check to ensure that the laminate film is correctly set. ● Check to ensure that the type of laminate film in use and the settings are appropriate.
05000056	Bottom side film is broken or is not detected.	
05000057	Mark on top side film is not detected.	
05000058	Mark on bottom side film is not detected.	<ul style="list-style-type: none"> ● Check to ensure that the laminate film is correctly set.
05000059	The laminator door is open.	<ul style="list-style-type: none"> ● Close the laminator door. If initialization does not start even after closing the laminator door, press the operation button to initialize.
0500005A	The film cassette is detached.	<ul style="list-style-type: none"> ● Insert the film cassette for the side to be laminated.
05000060	Thermostat is broken.	<ul style="list-style-type: none"> ● Turn off the power and turn it on again. If the same problem occurs, consult our authorized dealers or servicing personnel.
05000061	The temperature of the top side Heat Roller is too high.	
05000062	The temperature of the bottom side Heat Roller is too high.	
05000063	The internal temperature of the top side Heater is too high.	
05000064	The internal temperature of the bottom side Heater is too high.	
05000065	A hardware error has occurred in the top side Heat Roller.	
05000066	A hardware error has occurred in the bottom side Heat Roller.	
05000067	The thermistor of the top side Heat Roller is faulty.	
05000068	The thermistor of the bottom side Heat Roller is faulty.	
0500006B	A cam error has occurred in the top side Heat Roller.	
0500006C	A cam error has occurred in the bottom side Heat Roller.	
0500006D	The operating ambient temperature of the laminator is too low.	<ul style="list-style-type: none"> ● Use the laminator within the prescribed range. When starting up the laminator in a low temperature environment, the temperature of the interior may remain low even though the surrounding temperature has gone up. Turn on the power again after waiting for about one hour.
0500006E	A hardware error has occurred in the top side Film Supply Encoder.	<ul style="list-style-type: none"> ● Turn off the power and turn it on again. If the same problem occurs, consult our authorized dealers or servicing personnel.
0500006F	A hardware error has occurred in the bottom side Film Supply Encoder.	
05000070	A hardware error has occurred in the top side Film Takeup Encoder.	
05000071	A hardware error has occurred in the bottom side Film Takeup Encoder.	
0500007D	Other error is detected.	

Settings

[Laminator] Tab Sheet

- For changing laminator settings.

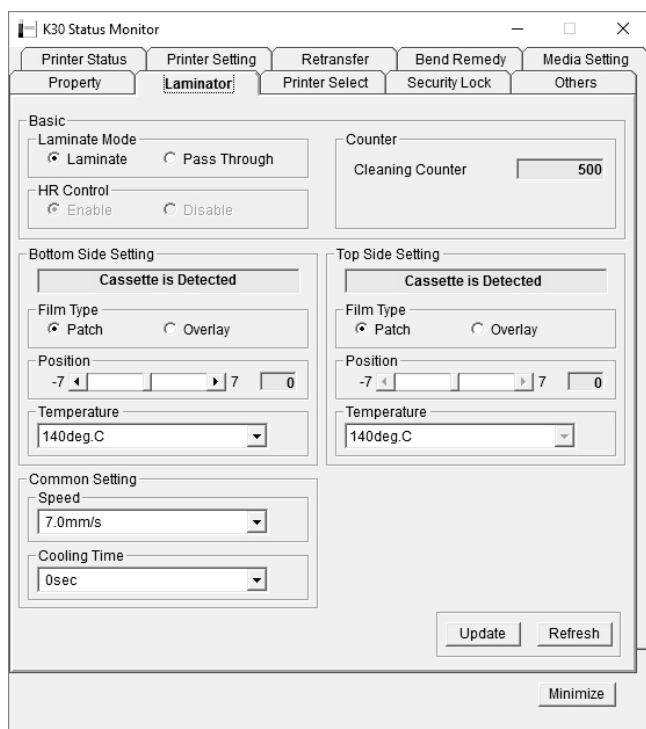

■ Basic

■ Laminate Mode

- Laminated
Laminates the card.
- Pass Through
Passes through the card without laminating.

■ HR Control

- This setting works simultaneously with the card printer setting. The default setting is [Enable]. For setting whether to standby the laminator by lowering the heating roller temperature if cards are not printed for 30 minutes or longer. This is always set to [Enable] automatically when overlay film is selected. (Regardless of the setting, turn off the heating roller and standby the laminator if you will not be performing card printing for a long time.)
- Settings can be changed on the [Printer Setting] tab sheet.

■ Counter

- Cleaning counter
Displays the number of laminations performed after the last roller cleaning. This number is reset to 0 each time roller cleaning is performed.

■ Bottom Side Setting/Top Side Setting

■ Cassette is Detected/No Cassette

- [Cassette is Detected] or [No Cassette] will be displayed for the bottom side film cassette and top side film cassette.
- [Film Type], [Position] and [Temperature] cannot be set in the [No Cassette] state.

■ Film Type

- Select the film type for the bottom side and top side film.
- For double-sided lamination, use the same type of laminate film for the top side and bottom side.
- Match the loaded laminate film with the [Film Type] setting.

■ Position

- For setting the patch position for the moving direction of the bottom side and top side film. The patch position can be adjusted to the left or right by 0.17 mm per step. (Refer to page 35 "Misaligned Patch Position")

■ Temperature

- For setting the temperature of the bottom side and top side heating roller. Settable range is between 90 °C and 180 °C. (A temperature of 185°C or higher may be selectable depending on the version of the status monitor. However, in this case, the temperature for the heating roller remains at 180 °C.)

■ Common Setting

■ Speed

- For setting the card feed speed during lamination.

■ Cooling Time

- For setting the standby time for cooling down the card immediately before lamination starts.

■ [Update] button

- The selected values will be set for the laminator.

■ [Refresh] button

- Display the setting status for the laminator on the screen.

Printer Driver Settings

[Laminate] Tab Sheet

- For setting the laminating operations.

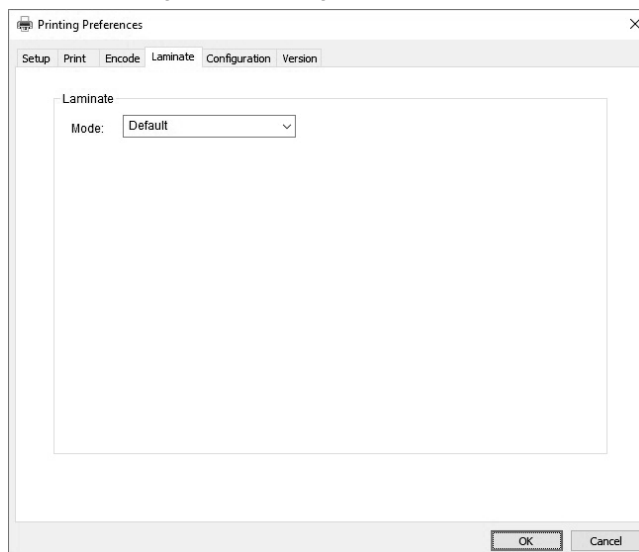

■ Mode

- Default:
Operates using the settings defined in "Laminate Mode" of the status monitor.
- Pass Through:
Does not laminate the card.
- Laminate:
Laminates the card.

Replacement

Laminate Film

- This laminator selects the side of the card to be laminated by the presence of the film cassette. Load the film cassette to the side of the card to be laminated.

Cautions:

- If the security lock of the card printer is on, deactivate it. After work is complete, activate the security lock again. For details on locking/unlocking the security lock, refer to the manual of the card printer.
- Stand the film cassette on a flat surface. Avoid doing so on a floor as dust attached to the film may cause poor adhesion or malfunction.
- A film cassette that has laminate film attached on it is heavy. Hold the film cassette with both hands to avoid dropping when working with it.
- If the laminate film is attached in the wrong direction, film detection error or lamination defects may occur. Attach the laminate film in the right direction.
- Match the loaded laminate film with the [Film Type] setting. If the laminate film and the setting do not coincide, film detection error occurs after the laminate film has been forwarded for a certain length.
- In the case of single-sided lamination, an error will occur if a film cassette that is not loaded with laminate film is attached to the side that is not to be laminated. Remove the film cassette from the side that is not to be laminated.
- For double-sided lamination, ensure that both the top side and bottom side film cassettes are attached. The absence of film cassette on either side will result in single-sided lamination.
- For double-sided lamination, use the same type of laminate film for the top side and bottom side. Using different types of laminate film may result in card jam or error.

1 Open the laminator door

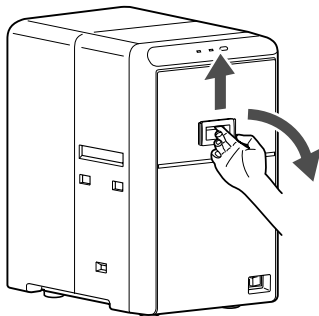

2 Remove any slack in the laminate film

- Turn the knob on the film cassette in the direction indicated by the arrow.

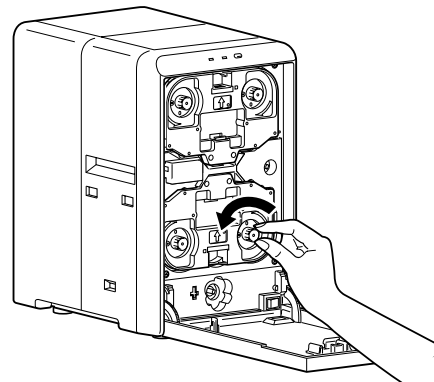
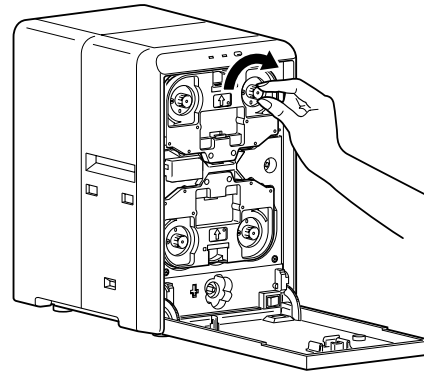

3 Press and hold down the cassette button, and pull out the film cassette

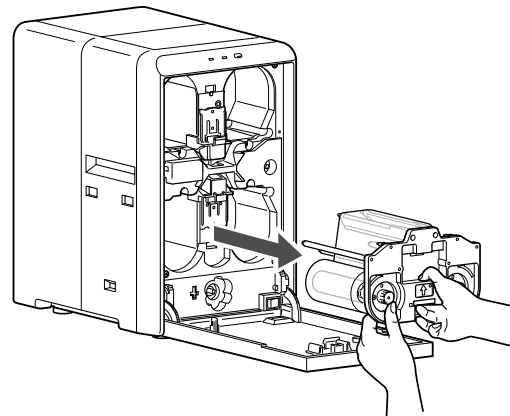
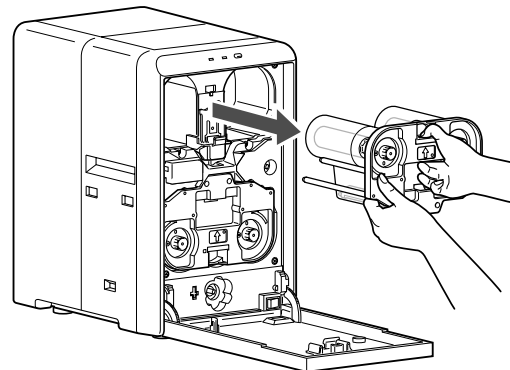

4 Remove the laminate film from the film cassette

Replacement

5 Attach the tip of the new laminate film to the bobbin

- ① Place the new laminate film and the take-up bobbin side by side on a clean and flat platform.
- ② Attach the tip of the new laminate film to the take-up bobbin using the fixing tape.

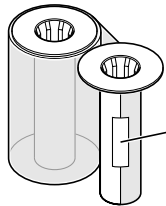

Use the fixing tape after peeling off the adhesive label of the laminate film.

Cautions:

- Attach the laminate film to the take-up bobbin such that they are parallel to each other. Otherwise, it may result in poor adhesion or cause film detection errors.

6 Install the new laminate film on the film cassette

- Install while referring to the indication on the label of the cassette.

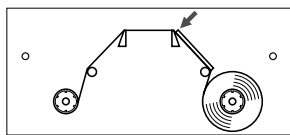

Top Side Film Cassette

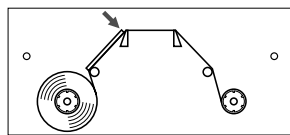

Bottom Side Film Cassette

- ① Insert the supply side of the film into the bobbin holder (patch position adjustment mechanism attached).
- ② Unwind the laminate film along the film guides, and insert the take-up side into the bobbin holder.

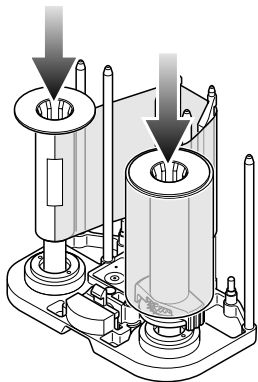

Top Side Film Cassette

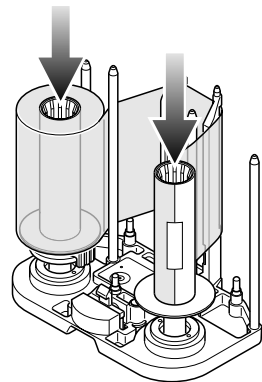

Bottom Side Film Cassette

- ③ Wind the film twice around the take-up side.

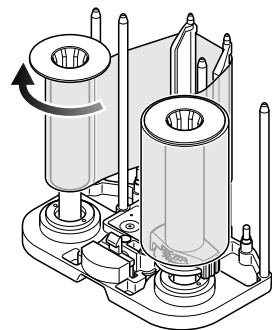

Top Side Film Cassette

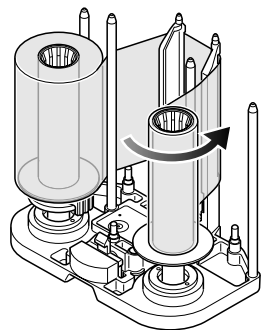

Bottom Side Film Cassette

7 Remove any slack in the laminate film

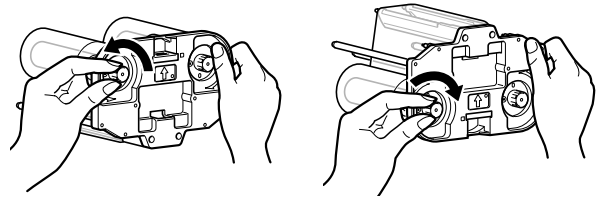

8 Insert the film cassette along the guide rail until a "click" sound is heard

- If the type of laminate film used is changed, change the setting on the status monitor according to the laminate film loaded.

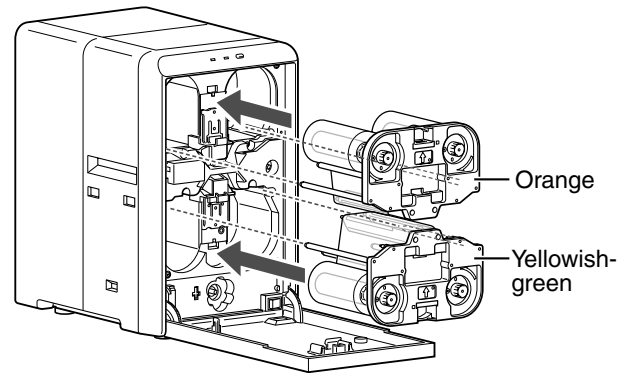

Cautions:

- Make sure to insert the film cassette all the way in until a "click" sound is heard. Failure to do so may result in defective patch or card jam.
- If the film cassette is inserted upside down, it cannot be inserted all the way in and the cassette button does not lock in place. Also, you will not be able to close the laminator door.

9 Close the laminator door

Cautions:

- If the loading status of the film cassette is changed when changing the side to be laminated, initialization will not be performed even when the laminator door is closed. In this case, press the operation button to initialize.

■ When the laminate film runs out during continuous card printing

- A [Retransfer] message is displayed on the card printer and the unit remains in the standby state until the laminator switches to the Ready mode.

<To continue printing>

- Card printing resumes automatically after exchanging the laminate film with a new one.

<To quit printing>

- As the card is still left inside the card printer, check to ensure that the operation of the card printer has come to a complete stop, followed by turning off the power. Open the printer door, and remove the retransfer film cassette. Align the film side of the unused portion with the arrow indicated on the cassette label. Restore the retransfer film cassette to the original position, close the printer door, and turn on the power of the card printer. Reset starts, and the card is discharged from the card printer.

Maintenance

- Film residue and dust may cause lamination defects if they are accumulated inside the laminator. Clean all parts regularly.

Cautions:

- After cleaning is complete, check to ensure that all dismantled parts are restored to their original positions. Failure to restore the parts may result in malfunction of the laminator.

Request for routine servicing

- In order to prevent printing errors and malfunctions from occurring in advance, please request for routine servicing by the servicing personnel. For details on servicing, please consult our authorized dealers.

Card Feed Roller/Heating Roller

- Lamination defects or card jam may occur if the card feed roller is dirty.
- Clean the card feed roller/heating roller of the laminator and card printer after laminating about 1,000 cards.

Cautions:

- If the security lock of the card printer is on, deactivate it. After work is complete, activate the security lock again. For details on locking/unlocking the security lock, refer to the manual of the card printer.
- Stand the film cassette on a flat surface. Avoid doing so on a floor as dust attached to the film may cause poor adhesion or malfunction.
- A film cassette that has laminate film attached on it is heavy. Hold the film cassette with both hands to avoid dropping when working with it.
- Each cleaning card can only be used once. Reusing a dirty card may dirty the roller or cause the laminator to malfunction. For details on the cleaning card, please consult our authorized dealers.
- Cleaning cannot be performed while the heating roller is still hot. Turn off the power, and perform cleaning after it has cooled down.

Cleaning the laminator together with the card printer

- 1 Open the laminator door

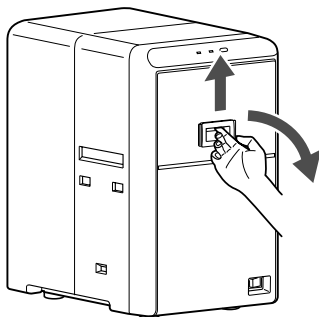

- 2 Press and hold down the cassette button, and pull out the film cassette

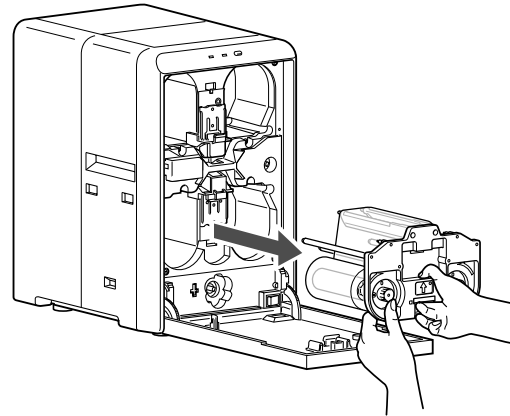
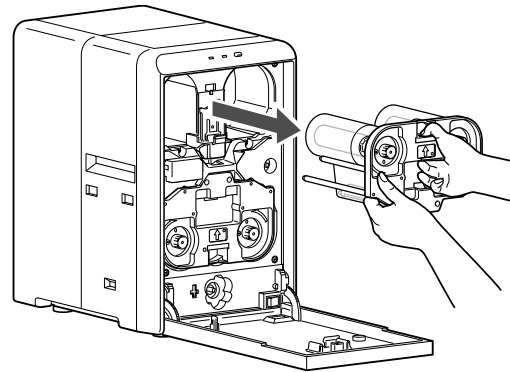

- 3 Close the laminator door, and turn on the power of the laminator
 - The LED display (red) starts blinking.

- 4 Remove the retransfer film cassette (left) from the card printer, close the printer door, and remove the card hopper

- 5 Turn on the power of the card printer, and set it to the card feed roller/heating roller cleaning mode
 - For details on cleaning of the card printer's card feed roller/heating roller, refer to the manual of the card printer.

- 6 Peel off the backing paper from the cleaning card (sold separately)



Maintenance

- 7** Insert the cleaning card (sold separately) into the card cleaner

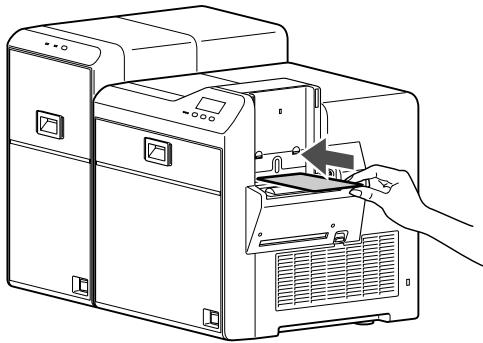

- The cleaning card is discharged from the card outlet of the laminator.

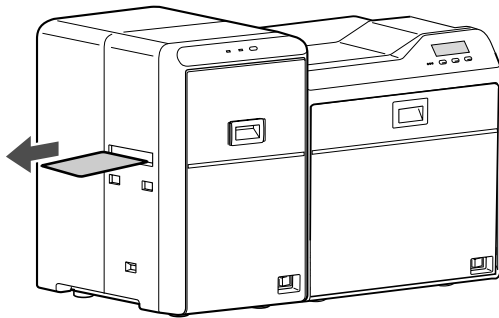

- 8** Reverse the adhesive face of the cleaning card, and insert it into the card printer again

- The cleaning card is discharged from the card outlet of the laminator.

- 9** Open the laminator door

- 10** Insert the film cassette all the way in along the guide rail until a “click” sound is heard, and close the laminator door

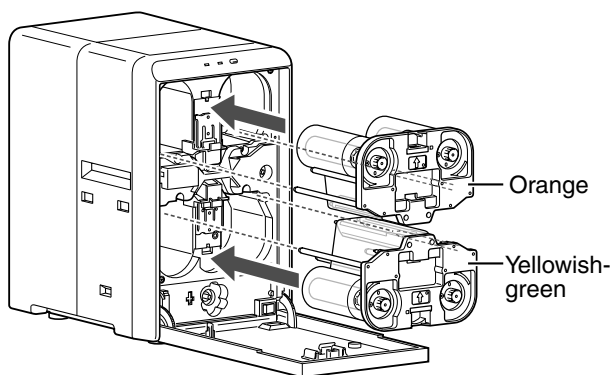

■ Cleaning the laminator alone

- 1** Open the laminator door

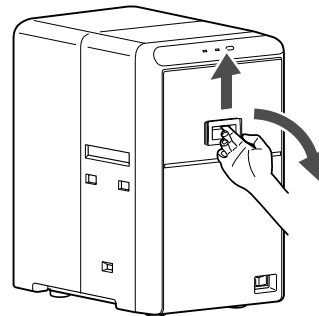

- 2** Press and hold down the cassette button, and pull out the film cassette

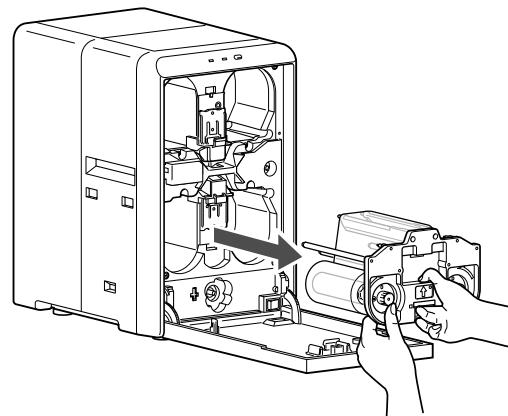
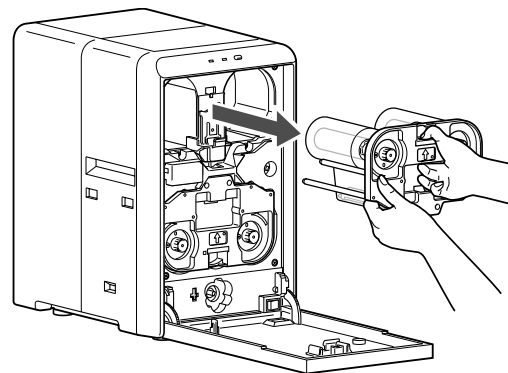

- 3** Close the laminator door, and turn on the power of the laminator

- The LED display (red) starts blinking.

Cautions:

- Make sure to insert the film cassette all the way in until a “click” sound is heard. Failure to do so may result in defective patch or card jam.
- If the film cassette is inserted upside down, it cannot be inserted all the way in and the cassette button does not lock in place. Also, you will not be able to close the laminator door.

-
- 4** Press the operation button for two seconds or longer

- The cleaning process starts.

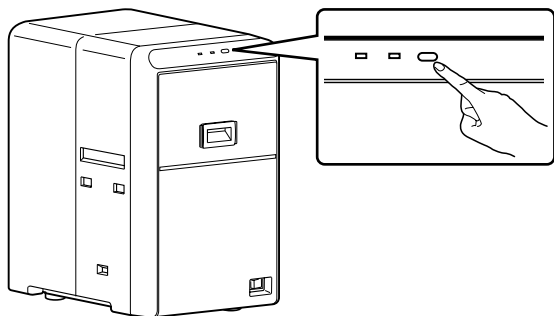

Cautions:

- The cleaning operation does not start if the heating roller is still hot. Turn off the power, and perform cleaning after the heating roller has cooled down completely.

-
- 5** Peel off the backing paper from the cleaning card (sold separately)

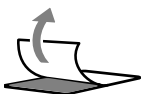

- 6** Insert the cleaning card (sold separately) into the card outlet of the laminator

- The card is drawn in by the roller. Cleaning starts automatically, and is discharged from the card outlet.

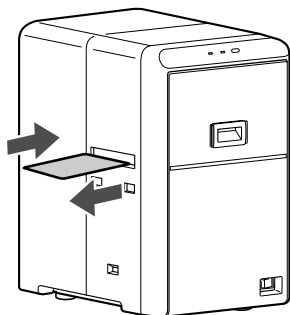

- 7** Press the operation button again for two seconds or longer, reverse the adhesive face of the cleaning card, and insert it into the card outlet

- The cleaning card is discharged from the card outlet of the laminator.

- 8** Open the laminator door

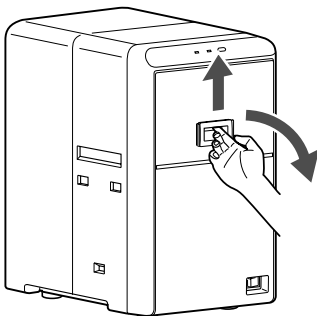

- 9** Insert the film cassette all the way in along the guide rail until a “click” sound is heard, and close the laminator door

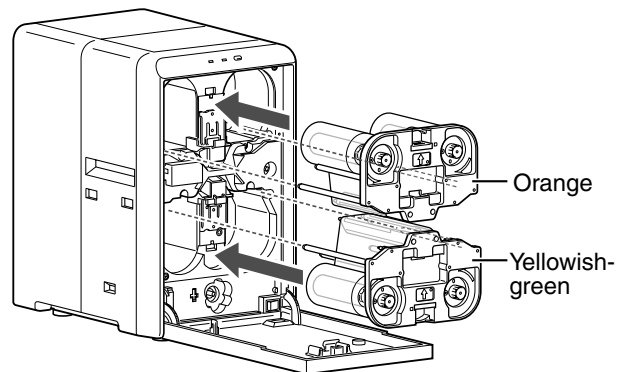

Cautions:

- Make sure to insert the film cassette all the way in until a “click” sound is heard. Failure to do so may result in defective patch or card jam.
- If the film cassette is inserted upside down, it cannot be inserted all the way in and the cassette button does not lock in place. Also, you will not be able to close the laminator door.

Maintenance

Fan Filter

Cautions:

- Start work after ensuring that the power has been turned off.
- Replace the fan filter with a new one after using it for about one year. For details on its replacement, please consult our authorized dealers.

1 Remove the filter cover at the back of the laminator

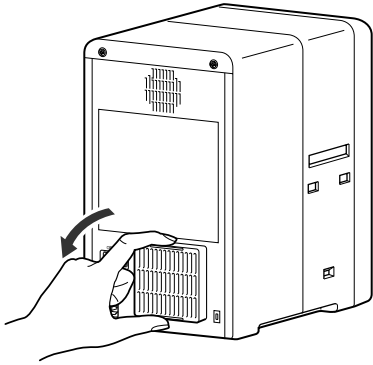

2 Remove the fan filter

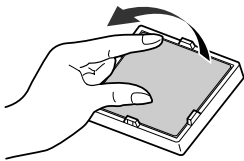

3 Remove any dirt that is attached to the fan filter using a vacuum cleaner

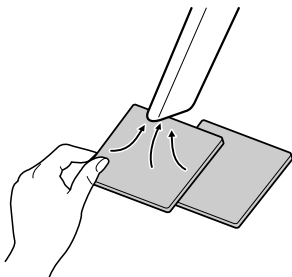

Cautions:

- Hold down the fan filter to avoid it from been sucked into the vacuum cleaner.

4 Set the fan filter

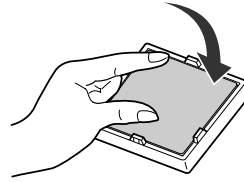

5 Set the filter cover

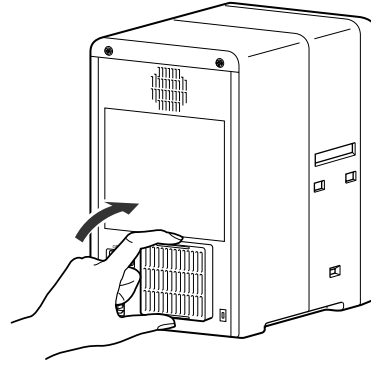

Film Cassette

- Due to the characteristics of the patch film, residues at the back of the laminate film may be attached to the film guide of the film cassette. Residues on the adhesive face of the laminate film may result in poor adhesion. When replacing the laminate film, check to ensure that no residues are attached to the film guides.

Cautions:

- If the security lock of the card printer is on, deactivate it. After work is complete, activate the security lock again. For details on locking/unlocking the security lock, refer to the manual of the card printer.
- Stand the film cassette on a flat surface. Avoid doing so on a floor as dust attached to the film may cause poor adhesion or malfunction.
- A film cassette that has laminate film attached on it is heavy. Hold the film cassette with both hands to avoid dropping when working with it.

1 Open the laminator door

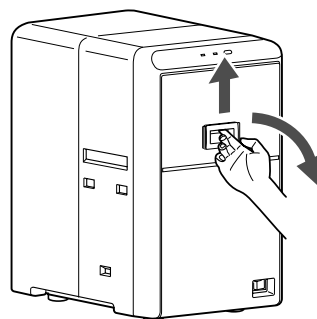

2 Remove any slack in the laminate film

- Turn the knob on the film cassette in the direction indicated by the arrow.

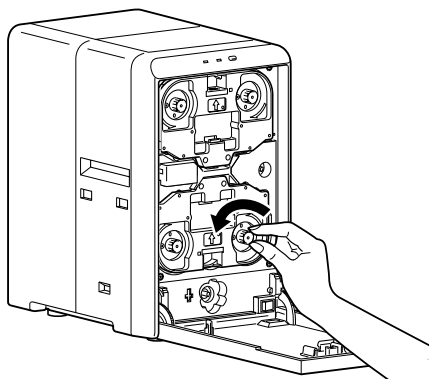
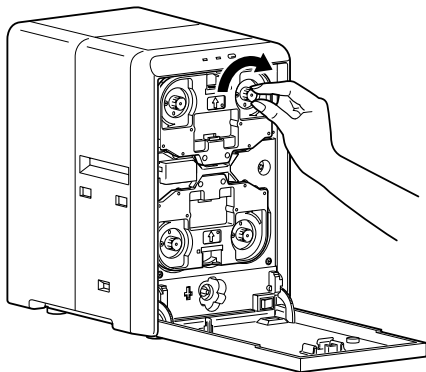

3 Press and hold down the cassette button, and pull out the film cassette

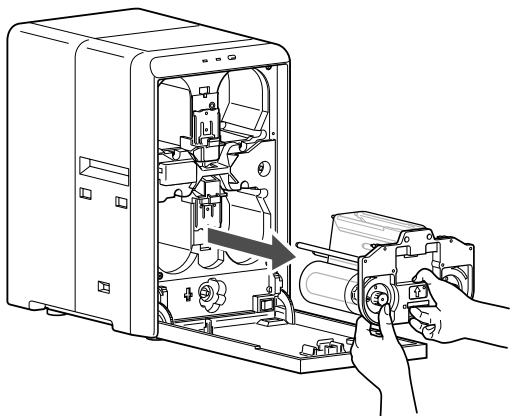
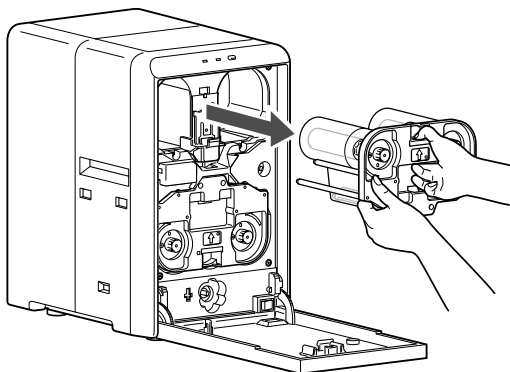

4 Remove the laminate film from the film cassette

5 Apply alcohol to a rag that does not produce lint easily (such as a cleaning wipe)

6 Wipe the four film guides

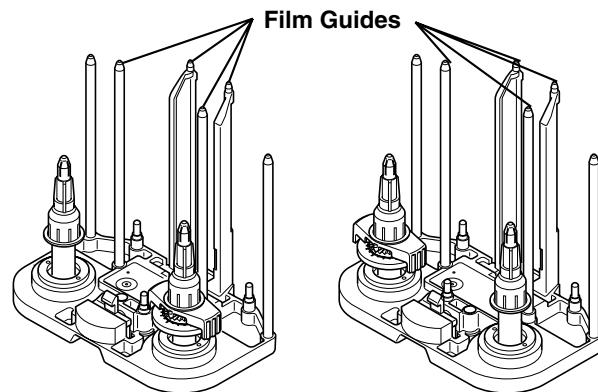

Top Side Film Cassette

Bottom Side Film Cassette

Cautions:

- Perform cleaning at a location away from the laminator so that residues do not enter the unit.

7 Install the laminate film on the film cassette

8 Remove any slack in the laminate film

9 Insert the film cassette all the way in along the guide rail until a “click” sound is heard, and close the laminator door

Cautions:

- Make sure to insert the film cassette all the way in until a “click” sound is heard. Failure to do so may result in defective patch or card jam.
- If the film cassette is inserted upside down, it cannot be inserted all the way in and the cassette button does not lock in place. Also, you will not be able to close the laminator door.

Interior of Laminator

- Dirt during card feed or burrs caused by friction between the bobbin holder and bobbin may adhere to the card or film, causing lamination defects as a result.

Cautions:

- Start work after ensuring that the power has been turned off.
- If the security lock of the card printer is on, deactivate it. After work is complete, activate the security lock again. For details on locking/unlocking the security lock, refer to the manual of the card printer.
- Stand the film cassette on a flat surface. Avoid doing so on a floor as dust attached to the film may cause poor adhesion or malfunction.
- A film cassette that has laminate film attached on it is heavy. Hold the film cassette with both hands to avoid dropping when working with it.

1 Open the laminator door

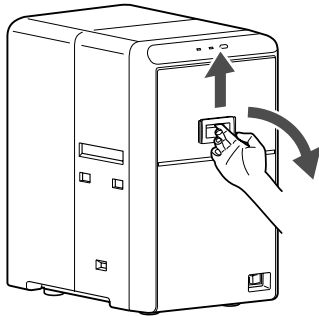

2 Remove any slack in the laminate film

- Turn the knob on the film cassette in the direction indicated by the arrow.

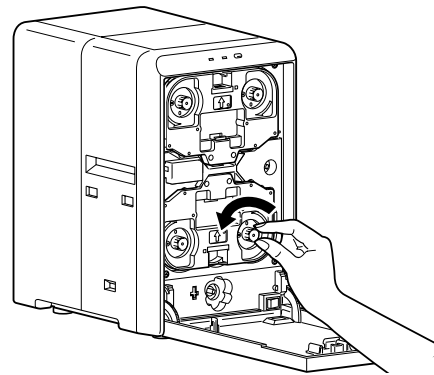
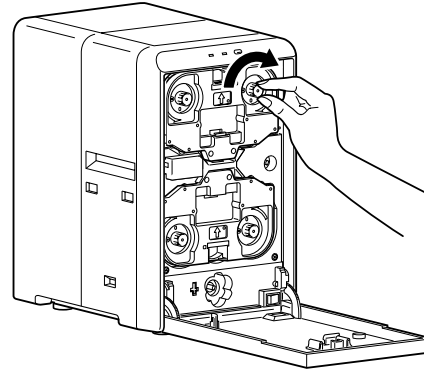

3 Press and hold down the cassette button, and pull out the film cassette

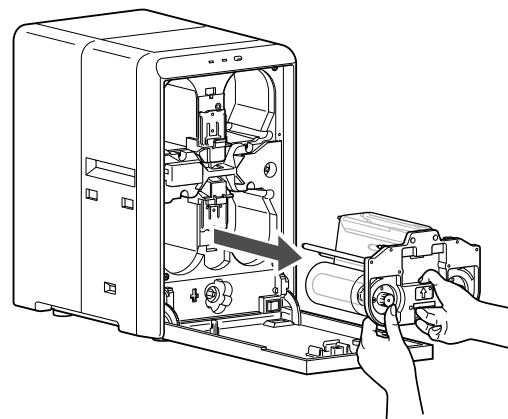
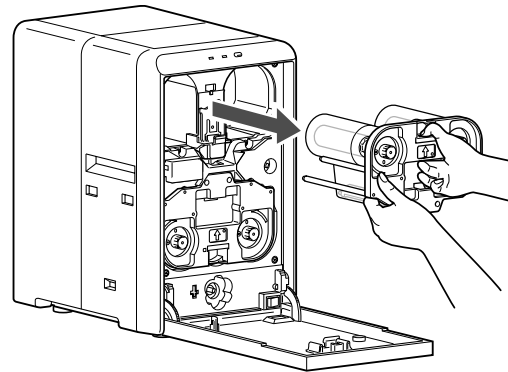

- 4** Apply alcohol to a cotton swab (large), and use it to wipe the bobbin holder (x4)

(Cotton swab and alcohol: sold separately)

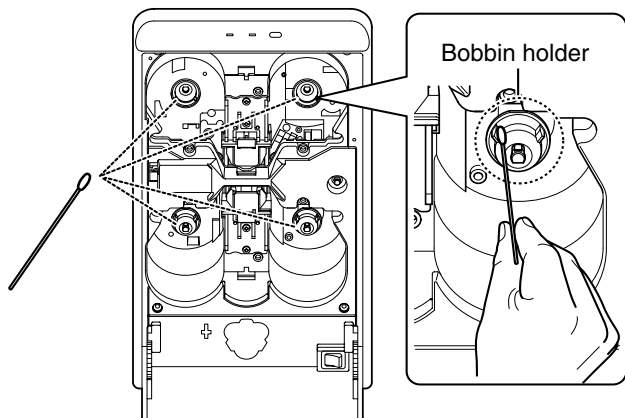

- 5** Apply alcohol to a cotton swab (large), and use it to wipe the guide rail (x2) at the back

Cautions:

- Do not touch the sensor and other parts inside the laminator. Doing so may cause the unit to malfunction.

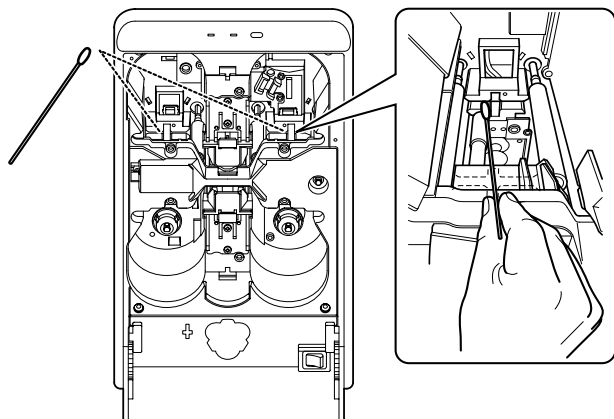

- 6** Apply alcohol to a cotton swab (small), and use it to wipe the guide rail (x2) in front

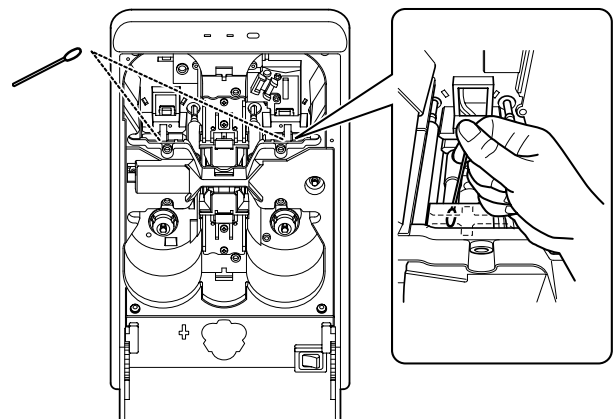

- 7** Remove any slack in the laminate film

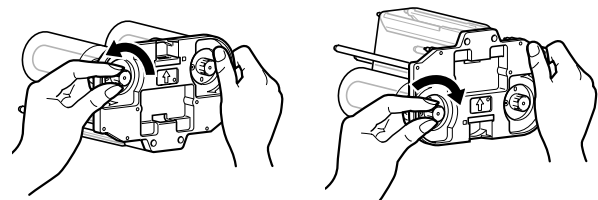

- 8** Insert the film cassette all the way in along the guide rail until a “click” sound is heard, and close the laminator door

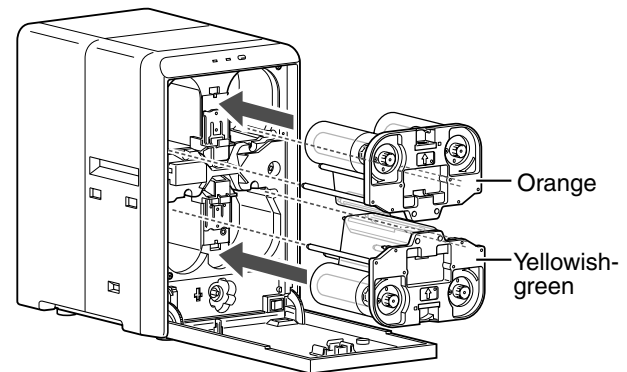

Cautions:

- Make sure to insert the film cassette all the way in until a “click” sound is heard. Failure to do so may result in defective patch or card jam.
- If the film cassette is inserted upside down, it cannot be inserted all the way in and the cassette button does not lock in place. Also, you will not be able to close the laminator door.

Card Jam

- Use the jog dial to remove the card. Make use of the jog dials that are supplied with the card printer.

Cautions:

- If the security lock of the card printer is on, deactivate it. After work is complete, activate the security lock again. For details on locking/unlocking the security lock, refer to the manual of the card printer.
- Stand the film cassette on a flat surface. Avoid doing so on a floor as dust attached to the film may cause poor adhesion or malfunction.
- A film cassette that has laminate film attached on it is heavy. Hold the film cassette with both hands to avoid dropping when working with it.

1 Check the position of the jammed card

- You can identify the position from the operation panel display of the card printer or the status monitor of the computer that is connected to the card printer.
- In the case of [Jam (In)], the card is automatically discharged when the laminator is reset. If the card is not discharged automatically, remove them by following the steps below.
- Do not reset the laminator in cases of [Jam (Middle)] and [Jam (Out)]. Remove them by following the steps below.

2 Open the laminator door

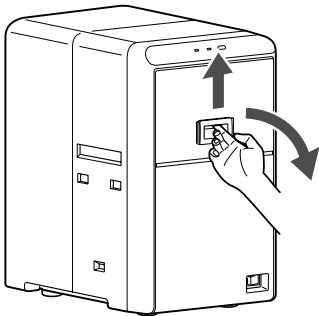

3 Remove any slack in the laminate film

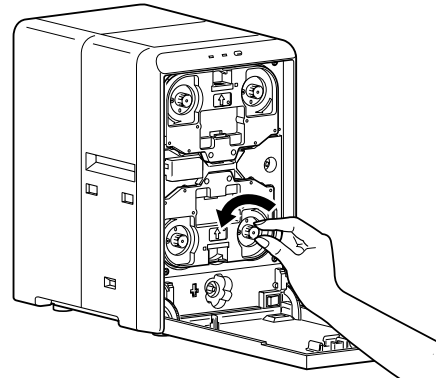
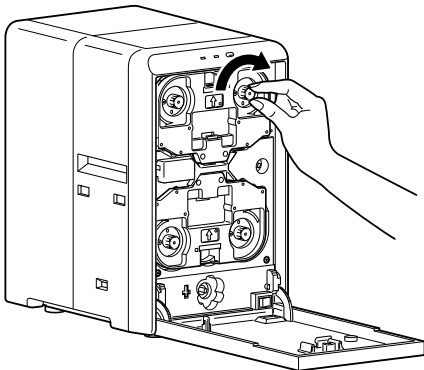

4 Press and hold down the cassette button, and pull out the film cassette

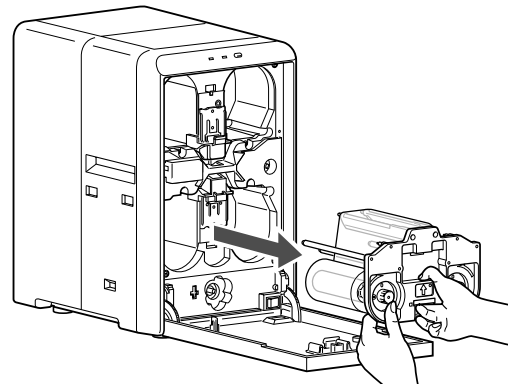
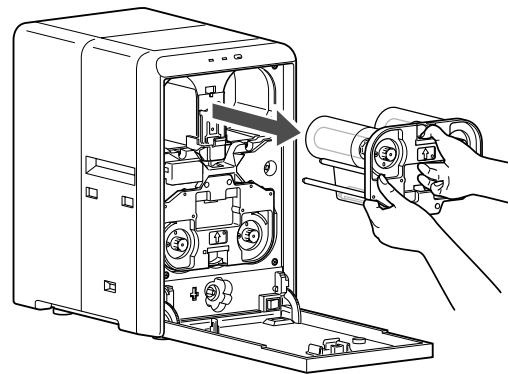

Cautions:

- The cassette may be difficult to pull out if the card is attached onto the laminate film. In this situation, pull out the cassette slowly to avoid dropping the laminate film from the film cassette while taking note of any slack on the film.

5 Remove the jog dial from the card printer

6 Attach the jog dial to the jog dial insertion slot

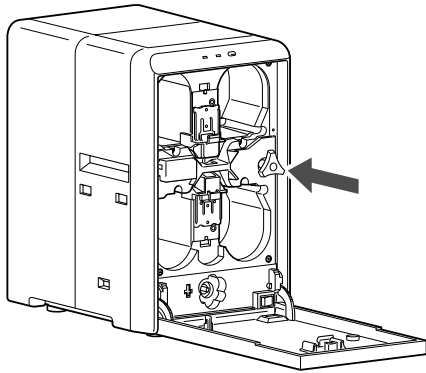

7 Turn the jog dial in the anti-clockwise direction

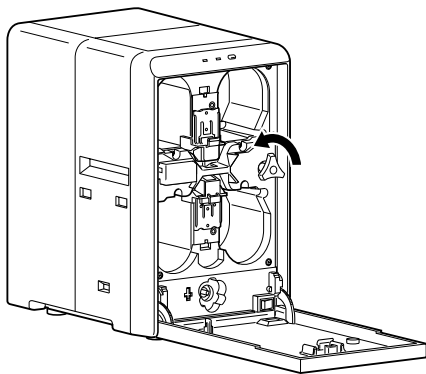

- The card is discharged from the card outlet.

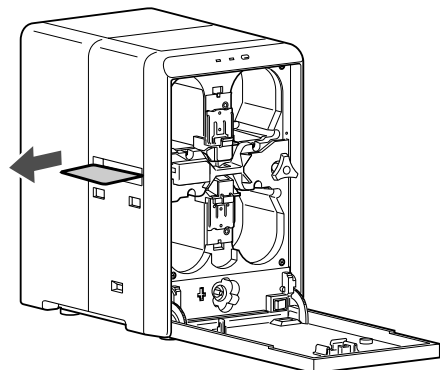

8 Restore the jog dial to its original position

9 Remove any slack in the laminate film

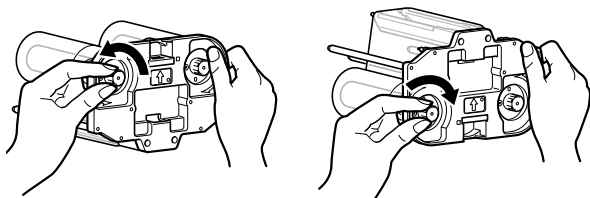

- If the film is entangled, refer to (☞ page 34 “Film is Entangled”).

10 Insert the film cassette all the way in along the guide rail until a “click” sound is heard, and close the laminator door

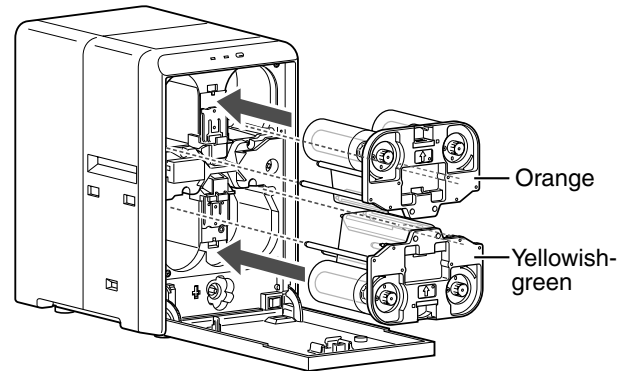

Cautions:

- Make sure to insert the film cassette all the way in until a “click” sound is heard. Failure to do so may result in defective patch or card jam.
- If the film cassette is inserted upside down, it cannot be inserted all the way in and the cassette button does not lock in place. Also, you will not be able to close the laminator door.

Film is Entangled

- When the film cassette is taken out and the film is entangled due to the laminate film been peeled off from the film cassette or card jams, use the methods below to untangle and reattach the film.

Cautions:

- If the security lock of the card printer is on, deactivate it. After work is complete, activate the security lock again. For details on locking/unlocking the security lock, refer to the manual of the card printer.
- Stand the film cassette on a flat surface. Avoid doing so on a floor as dust attached to the film may cause poor adhesion or malfunction.
- A film cassette that has laminate film attached on it is heavy. Hold the film cassette with both hands to avoid dropping when working with it.

■ If the laminate film is not damaged

- Install the new laminate film to the film cassette
 - Install while referring to the indication on the label of the cassette.

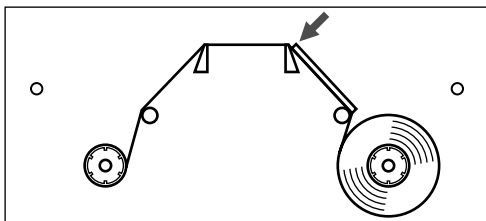

Top Side Film Cassette

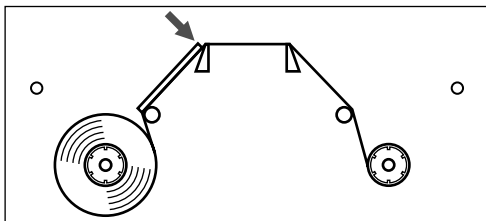

Bottom Side Film Cassette

- Turn the take-up side using your hand to take up the used portion of the film

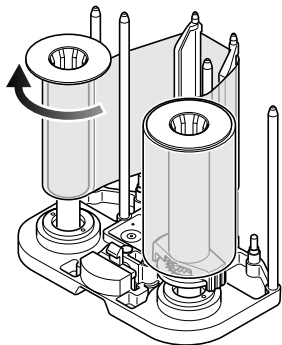

Top Side Film Cassette

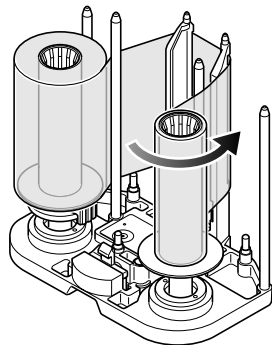

Bottom Side Film Cassette

- Remove any slack in the laminate film

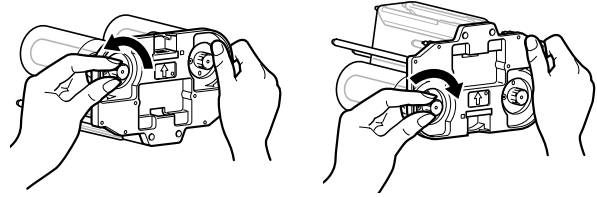

- Insert the film cassette all the way in along the guide rail until a “click” sound is heard, and close the laminator door

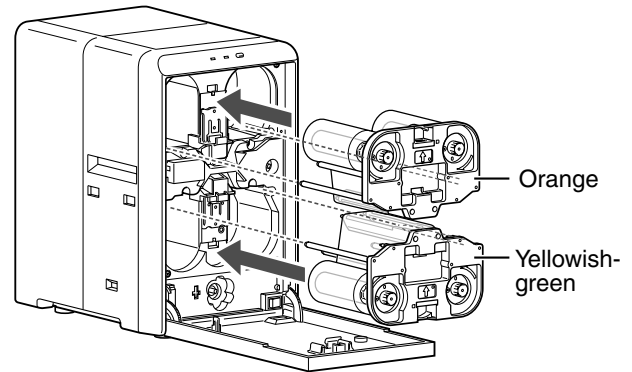

■ If the laminate film is damaged

- Cut away the damaged portion using a pair of scissors

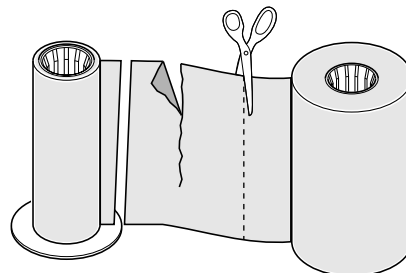

- Insert the supply side of the film into the bobbin holder (patch position adjustment mechanism attached), and the take-up side into the bobbin holder

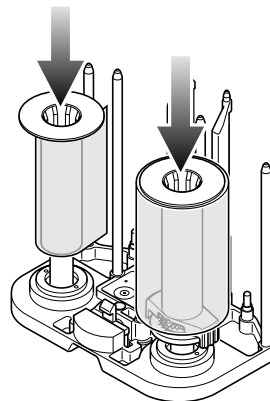

Top Side Film Cassette

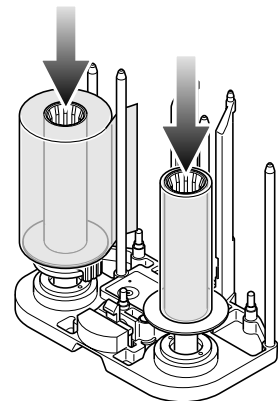

Bottom Side Film Cassette

- 3** Attach the unused portion at the supply side to the other end at the take-up side using an adhesive tape, while making sure that the joint surface is even

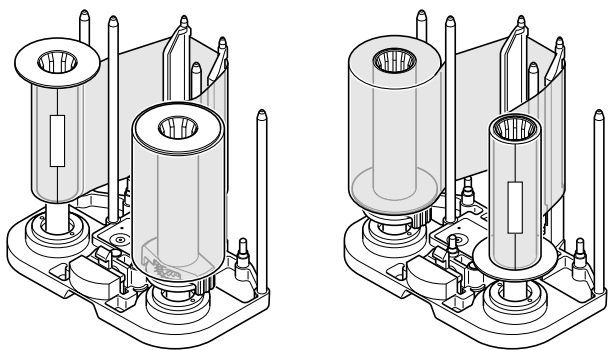

Top Side Film Cassette Bottom Side Film Cassette

- 4** Turn the take-up side using your hand until the broken portion can no longer be seen

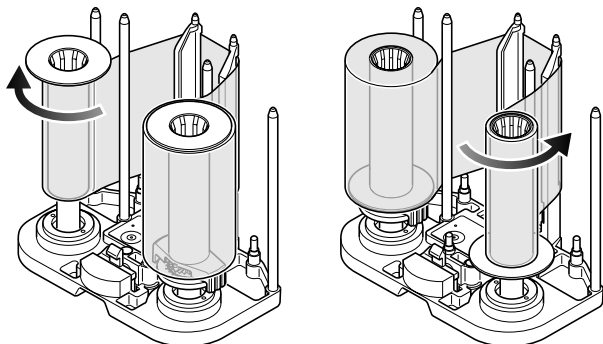

Top Side Film Cassette Bottom Side Film Cassette

- 5** Remove any slack in the laminate film

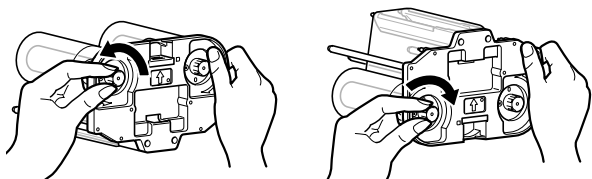

- 6** Insert the film cassette all the way in along the guide rail until a “click” sound is heard, and close the laminator door

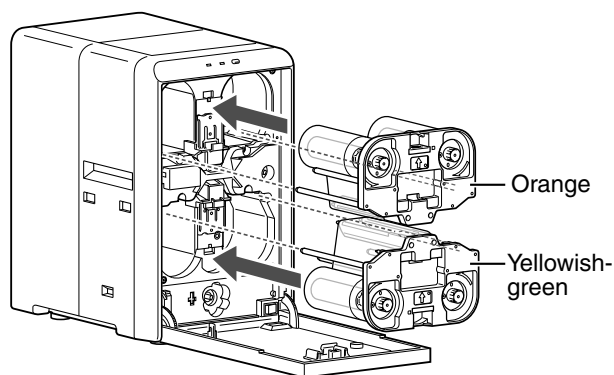

Cautions:

- Make sure to insert the film cassette all the way in until a “click” sound is heard. Failure to do so may result in defective patch or card jam.
- If the film cassette is inserted upside down, it cannot be inserted all the way in and the cassette button does not lock in place. Also, you will not be able to close the laminator door.

Misaligned Patch Position

- The patch position may vary slightly with respect to the card depending on the type of film used and the different methods used during the manufacturing process. If the patch position is not properly aligned, adjust it accordingly.

■ If patch position is displaced to the left/right

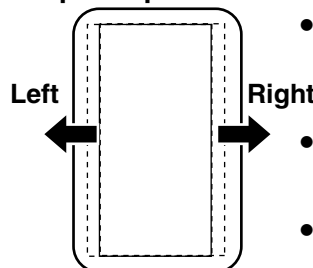

- You can adjust the setting on the status monitor of the computer that is connected to the card printer.
- The maximum displacement of the patch position is ± 7 steps from the standard position.
- The patch position can be adjusted to the left or right by 0.17 mm per step.
- Change the value in the + direction to move the patch position to the left.
- Change the value in the - direction to move the patch position to the right.
(See page 22 “Status Monitor Settings [Laminator] Tab Sheet”)

Cautions:

- Setting the patch position to a position beyond the edge of the card may result in card jams. Make sure to adjust the patch position nearer to the center of the card.

■ If patch position is displaced to the front/back

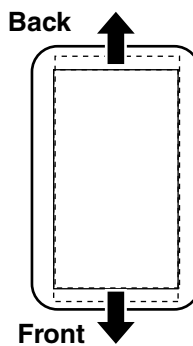

- Turning the patch position adjustment mechanism of the film cassette enables you to adjust the patch position to the front or back by 0.25 mm.
- The maximum displacement of the patch position adjustment mechanism is ± 1 mm from the standard position.
- Adjust the scale in the + direction to move the patch position to the back.
- Adjust the scale in the - direction to move the patch position to the front.

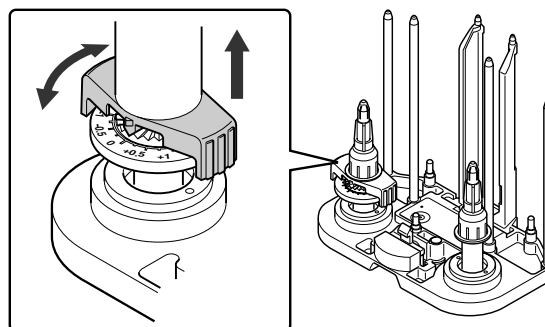

Cautions:

- Apply the above procedures if there is significant misalignment in the patch position.
- Do not rotate the patch position adjustment mechanism over ± 1 mm. Doing so may damage it.

Card Warpage

- During laminating, heating by the heating roller may cause warpage in cards with a low heat resistance, such as PVC ones.

■ If card is significantly warped

- Lowering the temperature or increasing the speed helps to reduce the heat load on the card, thus causing less warpage. Alter the temperature and speed gradually while making sure that the adhesiveness is not affected.
- Settings can be changed on the status monitor of the computer that is connected to the card printer.

Laminating Condition Settings

Cautions:

- If cards with low heat resistance are used, applying a large heat load at once causes the card to deform significantly, and this may in turn cause card jam inside the laminator unit. Alter the temperature and speed gradually.
- Reimbursement will not be done for poor adhesion or card warpage. For more information about the card, please consult our authorized dealers and evaluate the settings.

■ Setting example for double-sided printing and double-sided lamination (Heat-resistant PET-G card)

Film		1mil	0.6mil	Overlay	
Ambient Condition		Temperature	15 °C to 28 °C		
		Humidity	35 % to 60 %		
Laminator L10D	Temperature (Top Side)		150 °C	135 °C	120 °C
	Temperature (Bottom Side)		140 °C	125 °C	110 °C
	Speed		6.0 mm/s	7.0 mm/s	6.0 mm/s
	Cooling Time		0 sec		
Card Printer K30 Series	Retransfer Settings	Temperature Level	+2	+2	+2
		Speed (Front)	0	0	0
		Speed (Back)	+2	+2	+2
	Bend Remedy	Temperature Level	Off	Off	Off

■ Setting example for double-sided printing and top side lamination (Heat-resistant PET-G card)

Film		1mil	0.6mil	Overlay	
Ambient Condition		Temperature	15 °C to 28 °C		
		Humidity	35 % to 60 %		
Laminator L10D	Temperature (Top Side)		170 °C	165 °C	140 °C
	Speed		4.0 mm/s	5.0 mm/s	5.0 mm/s
	Cooling Time		0 sec		
Card Printer K30 Series	Retransfer Settings	Temperature Level	+2	+2	+2
		Speed (Front)	0	0	0
		Speed (Back)	+2	+2	+2
	Bend Remedy	Temperature Level	Off	Off	Off

■ **Setting example for double-sided printing and bottom side lamination
(Heat-resistant PET-G card)**

Film			1mil	0.6mil	Overlay
Ambient Condition		Temperature	15 °C to 28 °C		
		Humidity	35 % to 60 %		
Laminator L10D	Temperature (Bottom Side)		155 °C	155 °C	125 °C
	Speed		5.0 mm/s	12.0 mm/s	5.0 mm/s
	Cooling Time		0 sec		
Card Printer K30 Series	Retransfer Settings	Temperature Level	+2	+2	+2
		Speed (Front)	0	0	0
		Speed (Back)	+2	+2	+2
	Bend Remedy	Temperature Level	Off	Off	Off

■ **Setting example for single-sided printing and bottom side lamination
(Heat-resistant PET-G card)**

Film			1mil	0.6mil	Overlay
Ambient Condition		Temperature	15 °C to 28 °C		
		Humidity	35 % to 60 %		
Laminator L10D	Temperature (Bottom Side)		155 °C	160 °C	130 °C
	Speed		5.0 mm/s	12.0 mm/s	5.0 mm/s
	Cooling Time		0 sec		
Card Printer K30 Series	Retransfer Settings	Temperature Level	+2	+2	+2
		Speed (Front)	0	0	0
		Speed (Back)	+2	+2	+2
	Bend Remedy	Temperature Level	Off	Off	Off

List of Error Codes

LED displays and error codes

- The error codes are displayed on the operation panel of the card printer as well as the status monitor of the computer that is connected to the card printer.
- For error codes displayed on the status monitor, refer to page 21.

LED display (red)	LED display (blue)	Error Code	Error Content	Actions
Blinking (Slow)	Light off	Jam(In) 50	Card jam near the card feed port.	<ul style="list-style-type: none"> • Check to ensure that the laminator is properly connected to the card printer. (☞ page 11 “Card Printer Connection”) • Remove the jammed card. (☞ page 32 “Card Jam”)
		Jam (Middle) 51	Card jam near the heating roller.	<ul style="list-style-type: none"> • The temperature of the heating roller may be too high, or the card transfer speed may be too slow. For details on the optimal settings, please consult our authorized dealers. • Remove the jammed card. (☞ page 32 “Card Jam”)
		Jam(Out) 52	Card jam near the card outlet.	
		Film-T RunOut 53	The top side laminate film has run out.	<ul style="list-style-type: none"> • Replace the laminate film with a new one. (☞ page 23 “Laminate Film”)
		Film-B RunOut 54	The bottom side laminate film has run out.	
		Film-T Search 55	The top side laminate film cannot be detected.	<ul style="list-style-type: none"> • Check to ensure that the laminate film is correctly set. • Check to ensure that the type of laminate film in use and the settings are appropriate.
		Film-B Search 56	The bottom side laminate film cannot be detected.	
		Film-T Search 57	The top side laminate film cannot be detected.	<ul style="list-style-type: none"> • Check to ensure that the laminate film is correctly set.
		Film-B Search 58	The bottom side laminate film cannot be detected.	
		Door Open 59	The laminator door is open. Or the loading status of the film cassette has changed after opening and closing the laminator door.	<ul style="list-style-type: none"> • Close the laminator door. If initialization does not start even after closing the laminator door, press the operation button to initialize.
No Cassette 5A	Film cassette is not inserted.	<ul style="list-style-type: none"> • Insert the film cassette for the side to be laminated. 		
Blinking (Fast)	Light off	Thermostat 60	The thermostat is faulty.	<ul style="list-style-type: none"> • Turn off the power and turn it on again. If the same problem occurs, consult our authorized dealers or servicing personnel.
		HR-T Overheat 61	Top side heating roller temperature error. (temperature is too high)	
		HR-B Overheat 62	Bottom side heating roller temperature error. (temperature is too high)	
		Overheat-T 63	Top side internal temperature error. (temperature is too high)	
		Overheat-B 64	Bottom side internal temperature error. (temperature is too high)	
		Heater-T 65	The top side heater is faulty.	
		Heater-B 66	The bottom side heater is faulty.	

LED display (red)	LED display (blue)	Error Code	Error Content	Actions	
Blinking (Fast)	Light off	Thermistor-T 67	The top side heating roller thermistor is faulty.	<ul style="list-style-type: none"> Turn off the power and turn it on again. If the same problem occurs, consult our authorized dealers or servicing personnel. 	
		Thermistor-B 68	The bottom side heating roller thermistor is faulty.		
		Cam-T 6B	Top side heating roller pressing operation error.		
		Cam-B 6C	Bottom side heating roller pressing operation error.		
			Overcool 6D	Internal temperature error. (temperature is too low)	<ul style="list-style-type: none"> The operating ambient temperature is too low. Use the laminator within the prescribed range. When starting up the laminator in a low temperature environment, the temperature of the interior may remain low even though the surrounding temperature has gone up. Turn on the power again after waiting for about one hour.
			Supply ENC-T 6E	Top supply side motor encoder (rotation detection) error.	<ul style="list-style-type: none"> Turn off the power and turn it on again. If the same problem occurs, consult our authorized dealers or servicing personnel.
			Supply ENC-B 6F	Bottom supply side motor encoder (rotation detection) error.	
			Wind ENC-T 70	Top take-up side motor encoder (rotation detection) error.	
			Wind ENC-B 71	Bottom take-up side motor encoder (rotation detection) error.	
		Other Error 7D	Other errors		
-	-	COM Error	A communication error has occurred between the card printer and the laminator. The power of the laminator is off. Or, there was a misalignment in the positions of the laminator and the card printer and thus communication cannot take place.	<ul style="list-style-type: none"> Turn on the power for the laminator. Or fit the laminator and card printer to the unit connection adapter properly. 	

■ Error during continuous card printing

- If an error occurs on the laminator unit during continuous card printing, a [Retransfer] message is displayed on the card printer and the unit remains in the standby state until the laminator switches to the Ready mode after recovering from the error.
- For details on the methods of error recovery, refer to the "List of Error Codes".

Cautions:

- Do not turn off the power of the card printer or open the printer door until the [Retransfer] message appears on the card printer and its operation comes to a complete stop.

<To continue printing>

- Recover the error on the laminator. Card printing resumes automatically when recovery is complete and after the laminator switches to the Ready mode.

Cautions:

- Card printing will not resume if the power of the card printer is turned off or when the printer door is opened.

<To quit printing>

- Recover the error on the laminator.
- As the card is still left inside the card printer, check to ensure that the operation of the card printer has come to a complete stop, followed by turning off the power. Open the printer door, and remove the retransfer film cassette. Align the film side of the unused portion with the arrow indicated on the cassette label. Restore the retransfer film cassette to the original position, close the printer door, and turn on the power of the card printer. Reset starts, and the card is discharged from the card printer.

Card Laminator L10D
Instruction Manual



Japan

Kanematsu Corporation
2-1, Shibaura 1-chome, Minato-ku,
Tokyo 105-8005, Japan
TEL : 81-3-5440-8470

U.S.A.

Kanematsu USA Inc.
100 Randolph Road Somerset,
New Jersey 08873, U.S.A.
TEL : 1-732-271-7300

Germany

Kanematsu G.m.b.H.
Oststrasse 34, D-40211
Duesseldorf, Germany
TEL : 49-211-36890